

# **Basic Course Workbook Series Student Materials**

**Learning Domain 35  
Firearms/Chemical Agents  
Version 2.5**

**Basic Course Workbook Series  
Student Materials  
Learning Domain 35  
Firearms/Chemical Agents  
Version 2.5**

Copyright ©2005  
California Commission on Peace Officer Standards and Training  
All rights reserved.

Published 1999  
Revised July 2005  
Correction May 2015

This publication may not be reproduced, in whole or in part, in any form or by any means electronic or mechanical or by any information storage and retrieval system now known or hereafter invented, without prior written permission of the California Commission on Peace Officer Standards and Training, with the following exception:

California law enforcement or dispatch agencies in the POST program, POST-certified training presenters, and presenters and students of the California basic course instructional system are allowed to copy this publication for non-commercial use.

All other individuals, private businesses and corporations, public and private agencies and colleges, professional associations, and non-POST law enforcement agencies in-state or out-of-state may purchase copies of this publication, at cost, from POST as listed below:

From POST's Web Site:  
[www.post.ca.gov](http://www.post.ca.gov)  
Go to Ordering Student Workbooks

## POST COMMISSIONERS

Sandra Hutchens – Chair	Sheriff Orange County
Lai Lai Bui	Sergeant Sacramento Police Department
Robert Doyle	Sheriff Marin County
Joyce Dudley	District Attorney Santa Barbara County
Peter Kurylowicz	Deputy Sheriff Riverside County
Laren Leichter – Vice Chair	Deputy San Bernardino County Sheriff Department
Ron Lowenberg	Dean Criminal Justice Training Center Golden West College
Jim McDonnell	Sheriff Los Angeles County Sheriff Department
Sylvia Moir	Chief El Cerrito Police Department
Jethroe Moore, II	Public Member
Laurie Smith	Sheriff Santa Clara County
Larry Wallace Representing Kamala Harris Attorney General Ex-Officio Member	Director of Division of Law Enforcement



## **THE ACADEMY TRAINING MISSION**

The primary mission of basic training is to prepare students mentally, morally, and physically to advance into a field training program, assume the responsibilities, and execute the duties of a peace officer in society.



## **FOREWORD**

The California Commission on Peace Officer Standards and Training sincerely appreciates the efforts of the many curriculum consultants, academy instructors, directors and coordinators who contributed to the development of this workbook. The Commission extends its thanks to California law enforcement agency executives who offered personnel to participate in the development of these training materials.

This student workbook is part of the POST Basic Course Training System. The workbook component of this system provides a self-study document for every learning domain in the Basic Course. Each workbook is intended to be a supplement to, not a substitute for, classroom instruction. The objective of the system is to improve academy student learning and information retention and ultimately a police officer dedicated to service and committed to safety.

The content of each workbook is organized into sequenced learning modules to meet requirements as prescribed both by California law and the POST Training and Testing Specifications for the Basic Course.

It is our hope that the collective wisdom and experience of all who contributed to this workbook will help you, the student, to successfully complete the Basic Course and to enjoy a safe and rewarding career as a peace officer serving the communities of California.

**ROBERT A. STRESAK**  
Executive Director





# LD 35: Firearms/Chemical Agents

## Table of Contents

---

Topic	See Page
<b>Preface</b>	<b>iv</b>
Introduction	iv
How to Use the Student Workbook	v
<b>Chapter 1: Firearms Safety</b>	<b>1-1</b>
Overview	1-1
Firearms Safety	1-2
Range Safety	1-7
Safe Firearms Storage	1-12
Chapter Synopsis	1-16
Workbook Learning Activities	1-17
<b>Chapter 2: Basic Firearms Operation</b>	<b>2-1</b>
Overview	2-1
Semiautomatic Pistols and Magazines	2-3
Revolvers	2-14
Shotguns	2-20
Chapter Synopsis	2-28
Workbook Learning Activities	2-31

---

*Continued on next page*

## Table of Contents, Continued

Topic	See Page
<b>Chapter 3: Firearms Ammunition</b>	<b>3-1</b>
Overview	3-1
Ammunition Safety	3-3
Cartridge Ammunition	3-6
Shotgun Ammunition	3-10
Wound Ballistics	3-14
Chapter Synopsis	3-16
Workbook Learning Activities	3-18
<b>Chapter 4: Firearms Cleaning and Maintenance</b>	<b>4-1</b>
Overview	4-1
Safety Inspections	4-3
Cleaning Preparation Materials, Equipment and Environment	4-8
Cleaning and Maintenance of Firearms	4-13
Chapter Synopsis	4-27
Workbook Learning Activities	4-28
<b>Chapter 5: Basic Shooting</b>	<b>5-1</b>
Overview	5-1
Drawing and Holstering	5-3
Firearms Shooting Principles	5-6
Firearm Malfunctions	5-15
Shooting Under Low Light/Nighttime Conditions	5-22
Combat Shooting Skills	5-29
Combat Related Stress	5-37
Chapter Synopsis	5-47
Workbook Learning Activities	5-49

*Continued on next page*

## Table of Contents, Continued

---

<b>Topic</b>	<b>See Page</b>
<b>Chapter 6: Chemical Agents</b>	<b>6-1</b>
Overview	6-1
Legal Issues Regarding Use and Possession	6-3
Safe and Effective Use	6-8
OC (Oleoresin Capsicum)	6-19
CN (Chloroacetophenone) and CS (Ortho-chlorobenzylidene-malononitrile)	6-23
Gas Masks	6-28
Chapter Synopsis	6-34
Workbook Learning Activities	6-36
<b>Supplementary Material</b>	<b>S-1</b>
<b>Glossary</b>	<b>G-1</b>

---

*Continued on next page*

## Table of Contents, Continued

---

This page was intentionally left blank.

---

# How to Use the Student Workbook

---

## Introduction

This workbook provides an introduction to the training requirements for this Learning Domain. It is intended to be used in several ways: for initial learning prior to classroom attendance, for test preparation, and for remedial training.

---

## Workbook format

To use the workbook most effectively, follow the steps listed below.

Step	Action
1	Read the first two sections: Preface and How to Use the Workbook, which provide an overview of how the workbook fits into the POST Instructional System and how it should be used.
2	Refer to the overview section at the start of each chapter to review the learning objectives.
3	Read the text.
4	Refer to the Chapter Synopsis section at the end of each chapter to review the key points that support the chapter objectives.
5	Complete the Workbook Learning Activities at the end of each chapter. These activities reinforce the material taught in the chapter.
6	Refer to the Glossary section for a definition of important terms. The terms appear throughout the text and are bolded and underlined the first time they appear (e.g., <b><u>term</u></b> ).

---

# Preface

## Introduction

---

### **Student workbooks**

The student workbooks are part of the POST Basic Course Instructional System. This system is designed to provide students with a self-study document to be used in preparation for classroom training.

---

### **Regular Basic Course training requirement**

Completion of the Regular Basic Course is required, prior to exercising peace officer powers, as recognized in the California Penal Code and where the POST-required standard is the POST Regular Basic Course.

---

### **Student workbook elements**

The following elements are included in each workbook:

- chapter contents, including a synopsis of key points
  - supplementary material
  - a glossary of terms used in this workbook
-

# Chapter 1

## Firearms Safety

### Overview

---

**Learning need** Peace officers must know and practice all procedures for the safe handling of all firearms while on and off duty.

---

**Learning objectives** The chart below identifies the student learning objectives for this chapter.

<b>After completing study of this chapter, the student will be able to:</b>	<b>E.O. Code</b>
• State the four fundamental rules of firearms safety	35.01.EO1
• Explain basic safety guidelines to be followed at a firing range	35.01.EO2
• Describe the safety precautions for proper storage of firearms	35.01.EO3

---

**In this chapter** This chapter focuses on firearms safety. Refer to the following chart for specific topics.

<b>Topic</b>	<b>See Page</b>
Firearms Safety	1-2
Range Safety	1-7
Safe Firearm Storage	1-12
Chapter Synopsis	1-16
Workbook Learning Activities	1-17

---

# Firearms Safety

[35.01.EO1]

---

## Introduction

A firearm is a precision instrument designed to function reliably with proper care and caution. Although many safety features have been incorporated into each firearm by the manufacturer, only the safe firearm handling habits by the officer will ensure its safe use.

---

## Leadership

Peace officers are authorized to use **deadly force** only as a last resort and only under the strictest of limitations and restraints. An officer who is highly skilled in the use of firearms and the decision-making process that leads to the use of deadly force will have better control of the situation and apply the appropriate force options.

---

## Ethics

Every officer is responsible for firearms safety, both on and off duty. Following basic firearms safety rules will greatly reduce the chances of a negligent **discharge** or an accident in the home. The officer is responsible for ensuring that his or her weapon is clean, oiled, and serviceable. A dirty, unlubricated firearm is as much an indicator of negligence and lack of pride as a dirty or torn uniform. More critically, poor weapons maintenance can mean the difference between life and death for an officer or an innocent member of the public.

---

## Unintentional discharges

Safe firearm handling is every officer's personal and professional responsibility. **Accidents do not just happen.**

Unintentional discharges are the result of:

- violating the rules of firearms safety
  - inadequate knowledge or skill regarding the operation and use of the firearm
  - improper or inadequate care and maintenance
  - poor judgement or lack of common sense
- 

*Continued on next page*



## Firearms Safety, Continued

---

### Unintentional discharges (continued)

Example: A firearm discharged unintentionally because of a mechanical breakdown. Even though all safety rules had been observed, the discharge was not an accident. The mechanical breakdown that led to the discharge was actually due to poor maintenance on the part of the officer.

---

### Fundamental rules

All firearms are deadly weapons. Lack of awareness or attention to safety for even a moment can cause deadly consequences. There are four fundamental rules of firearms safety that must be respected and obeyed at all times with **no exceptions**.

The following table identifies the four fundamental rules of firearms safety:

<b>Fundamental Rules of Firearms Safety</b>	<b>Explanation</b>
<b>Rule 1:</b>  Treat all firearms as if they are loaded.	<ul style="list-style-type: none"><li>• No one is capable of telling from a glance whether a firearm is loaded or unloaded</li><li>• Every time a firearm is handled, it should be checked to verify whether or not there is a round in the chamber</li><li>• If an officer is unable to check a firearm to determine if it is loaded, the firearm should be left alone. The officer should seek help from someone with more knowledge about the firearm</li><li>• When a firearm is handed from one person to another, both the giver and the receiver should check the firearm to verify whether or not there is a round in the chamber</li></ul>

---

*Continued on next page*

## Firearms Safety, Continued

**Fundamental rules**  
(continued)

<b>Fundamental Rules of Firearms Safety</b>	<b>Explanation</b>
<p><b>Rule 2:</b></p> <p>Always keep the firearm pointed in the safest possible direction.</p>	<ul style="list-style-type: none"> <li>• Always be aware of where the barrel of the firearm is pointing</li> <li>• A “safe direction” is one where an unintentional discharge of the firearm will not hurt the person handling the firearm or others</li> <li>• A firearm should only be pointed at a target if the officer is willing and prepared to shoot</li> </ul>
<p><b>Rule 3:</b></p> <p>Always keep fingers off the trigger until ready to fire the firearm.</p>	<ul style="list-style-type: none"> <li>• The officer’s finger should rest on the outside of the trigger guard or along the frame of the firearm until ready to fire</li> </ul>
<p><b>Rule 4:</b></p> <p>Be sure of the target and what’s beyond it before firing the firearm.</p>	<ul style="list-style-type: none"> <li>• Be aware that if the projectile misses or completely passes through the target, it could strike an unintended person or object</li> <li>• Clearly identify the target before firing</li> <li>• Never fire at a movement, color, sound, or shape unless it can be clearly identified</li> <li>• Officers should be aware of all persons around them before they fire a firearm to make sure no one is moving into the line of fire</li> </ul>

*Continued on next page*

## Firearms Safety, Continued

---

### Agency policies

The four fundamental rules set the foundation for all firearms safety. Every agency may have additional rules and regulations regarding the safe handling of firearms by peace officers.

NOTE: Officers are responsible for knowing and obeying their own agency's specific rules and regulations regarding the safe handling of all firearms.

---

### Examples

- (1) After cleaning his firearm, an officer wanted to check to make sure his firearm was functioning properly. He loaded what he thought was an empty magazine into the firearm, pointed it at his garage wall and pulled the trigger. The single cartridge that remained in the magazine was chambered and fired, and went through the wall and into the side of his neighbor's house. Fortunately, no one was injured. The officer had failed to obey three of the four fundamental rules of handling firearms.
  - (2) An officer placed her finger inside the trigger guard, thinking it would give her more control as she was drawing the firearm from its holster. Instead, as she gripped the firearm, she pulled the trigger. A round was fired and struck the officer in her leg. The officer failed to keep her finger away from the trigger until she was ready to fire.
- 

*Continued on next page*

## Firearms Safety, Continued

---

**Examples**  
(continued)

- (3) An officer placed his own backup firearm in his gym bag as he was preparing to leave the locker room at the end of his shift. Assuming the firearm was safe because there was no magazine loaded, he casually tossed the bag into the trunk of his car and a round that had been in the firearm's chamber was fired. The officer failed to obey the first fundamental rule of firearms safety: always treat the firearm as if it had been loaded.
-

# Range Safety

[35.01.EO2]

---

## Introduction

Every firing range will have specific safety rules that officers must be aware of and follow. There are also a number of basic safety guidelines that apply to all firing ranges.

---

## Range safety guidelines

A firing range consists of a firing line and targets. Officers are positioned on the firing line and fire at the targets. The following table identifies the basic guidelines for range safety:

When...	officers MUST...
entering the firing range	<ul style="list-style-type: none"><li>• <b>listen carefully for range commands and obey them instantly</b></li><li>• request clarification if a command is not clear or was not completely heard</li><li>• always wear approved eye and ear protection</li><li>• keep firearm in its holster until instructed to remove it by the instructor or range master (with the safety snap or strap in place)</li></ul>
on the firing line	<ul style="list-style-type: none"><li>• <b>listen carefully for range commands and obey them instantly</b></li><li>• request clarification if a command is not clear or was not completely heard</li><li>• keep the barrel pointed in a safe direction</li><li>• talk only when the instructor or range master speaks to them directly</li><li>• never allow the barrel of the firearm to point toward others</li></ul>

---

*Continued on next page*

## Range Safety, Continued

**Range  
safety  
guidelines  
(continued)**

When...	officers MUST...
on the firing line (continued)	<ul style="list-style-type: none"> <li>• raise their nonshooting hand to gain the instructor's or range master's attention if they have a question or see a safety violation (keeping the firearm pointed down range)</li> <li>• never proceed forward of the firing line except when commanded to do so</li> <li>• only put a finger on the trigger just prior to intended firing</li> <li>• never attempt to pick up any item that has dropped on the ground unless instructed to do so</li> <li>• stop firing immediately on command</li> </ul>
handguns are unholstered	<ul style="list-style-type: none"> <li>• <b>listen carefully for range commands and obey them instantly</b></li> <li>• request clarification if a command is not clear or was not completely heard</li> <li>• have the slide locked back and the magazine removed if using a <b><u>semiautomatic pistol</u></b></li> <li>• have the cylinder open if using a revolver</li> </ul> <p>NOTE: Firearms should be unholstered only when on the firing line.</p>

*Continued on next page*

## Range Safety, Continued

---

### Firearm location

While on a firing line, an officer can be easily distracted by noise or the actions of others, or when receiving guidance from an instructor. It is absolutely critical that officers always remain conscious of the location of their firearms.

The following table identifies the only acceptable locations for firearms while at a firing range:

While on the firing line of a range...	
<p><i>handguns</i> should always be:</p> <ul style="list-style-type: none"><li>pointed only at the target</li><li>in a low ready or close contact position, <i>or</i></li><li>in the holster</li></ul>	<p><i>shotguns</i> should always be:</p> <ul style="list-style-type: none"><li>pointed only at the target</li><li>in a ready position</li><li>slung on the shoulder, <i>or</i></li><li>in a shotgun storage rack unloaded with the action open and with the safety on</li></ul>

### Dry firing

**Dry firing** is the act or result of firing the firearm when it is not loaded, for the purpose of practice shooting or testing the firearm.

While at a firing range, a firearm should be dry fired *only*:

- when instructed to do so, *and*
- after the firearm has been visually and physically checked to make sure there is no round in the chamber

A firearm should never be dry fired in a location where an unintentional discharge could cause injury or death to another person.

---

*Continued on next page*

## Range Safety, Continued

---

### **Malfunctions on a firing range**

Any firearm can **malfunction** or misfire. If a malfunction or misfire takes place while shooting on a firing range, officers should:

- remove their trigger finger from the trigger
- keep the firearm pointed safely down range toward the target
- keep fingers off the trigger
- raise the nonshooting hand and wait for direction from the range master or instructor

If officers have already received specific instructions on how to clear common firearm malfunctions, they may follow those procedures for clearing the malfunction. If attempts to clear the firearm fail, officers should obtain assistance immediately.

---

### **Personal responsibility**

Along with obeying all rules of safety, officers must take personal responsibility to make sure that they are capable of functioning appropriately when handling a firearm.

Officers should never handle a firearm if they:

- have consumed alcoholic beverages
- have taken drugs or medications that could impair their ability or reflexes

NOTE: Medications can include both over-the-counter medications as well as prescription drugs.

---

### **Safety as routine**

All safety rules and guidelines should be continuously practiced by officers until they become natural and part of a normal routine. Even then, officers must make a conscious effort to recognize the importance of firearms safety.

**Checking a second time is never a waste of time.**

---

*Continued on next page*



## Range Safety, Continued

---

### Examples

- (1) An officer's firearm malfunctioned while the officer was on the firing line at a local range. The officer was not sure how to clear the malfunction so she raised her hand to gain the range officer's attention. As she moved her body to look around, she inadvertently pointed the firearm away from the target and toward the person next to her. By failing to keep the firearm pointed down range, the officer placed others in danger.
  - (2) An officer's flashlight fell from his utility belt while the officer was participating in an exercise on the firing line. When the officer finished shooting the designated rounds, he took two steps forward to retrieve the flashlight, even though others on the line were still firing and there had been no command to stop firing given yet. By moving forward of the firing line, the officer was placing himself in danger.
  - (3) During a timed exercise, an officer was concentrating so hard on his own performance that he failed to hear a command to stop firing before the allotted time was over. The officer was placing others on the firing range in danger by not always listening for and immediately obeying all range commands.
-

# Safe Firearms Storage

[35.01.EO3]

---

## **Introduction**

Most officers take their firearms home. Officers are responsible for properly and safely storing all firearms.

---

## **Safety precautions**

All firearms must be kept out of reach of children and immature or irresponsible adults. To ensure safety, officers should:

- keep all firearms inaccessible from children and other unauthorized persons
  - store ammunition separately from firearms
  - take all precautions against theft by storing firearms in a secure location and in a locked container. If no secure container is available, a locking device should be used or the firearm should be disassembled before storing
- 

*Continued on next page*

## Safe Firearms Storage, Continued

---

### Criminal storage of a firearm

*Penal Code Section 25110(a)* states: “Except as provided in *Section 25105* a person commits the crime of “criminal storage of a firearm of the first degree” if he or she keeps any loaded firearm within any premises that are under his or her custody or control and he or she knows or reasonably should know that a child is likely to gain access to the firearm without the permission of the child’s parent or legal guardian, and the child obtains access to the firearm and thereby causes...”

<ul style="list-style-type: none"> <li>• <b>death or great bodily injury</b></li> <li>• to himself, herself or any other person</li> </ul>	First degree
<ul style="list-style-type: none"> <li>• <b>injury other than death or great bodily injury</b></li> <li>• to himself, herself or any other person</li> <li>• exhibits the firearm in a public place</li> <li>• in violation of Penal Code Section 417 (drawing, exhibiting or unlawful use of a firearm)</li> </ul>	Second degree

### Classification

Criminal storage of a firearm of the first degree is a felony.  
(*Penal Code Section 25110(a)*)

Criminal storage of a firearm of the second degree is a misdemeanor.  
(*Penal Code Section 25110(a)*)

*Continued on next page*

## Safe Firearms Storage, Continued

### Exceptions to the law

*Penal Code Section 25100(a)* identifies a number of exceptions to the law regarding the criminal storage of a firearm. The following table identifies these:

<i>The crime of criminal storage of a firearm has not been committed if...</i>	
the child	<ul style="list-style-type: none"> <li>obtained the firearm as a result of an <i>illegal entry</i></li> <li>obtained or discharged the firearm in <i>self-defense</i> or in the defense of another person</li> </ul>
the firearm	<ul style="list-style-type: none"> <li>was kept in a locked container or in a secure location</li> <li>was carried on the person who possessed it or was in that person's close proximity</li> <li>was equipped with a locking device</li> <li>was possessed by a peace officer or member of the armed services <i>and</i> the child obtained the firearm incidental to the performance of that person's duties</li> </ul>
the person who possesses the firearm	<ul style="list-style-type: none"> <li>had no reasonable expectation, based on objective facts and circumstances, that a child would likely be present on the premises</li> </ul>

NOTE: For more information regarding criminal storage of a firearm refer to LD 40: *Weapons Violations*

*Continued on next page*

## Safe Firearms Storage, Continued

---

### Examples

- (1) Each evening, Officer Jones placed his firearm in a metal container, locked the container, and stored it on the top shelf of a kitchen cabinet. One evening, when his parents were away, Officer Jones' 12-year-old son decided to show a new friend his dad's handgun. Although the boy knew the location of the firearm, he was not able to open or retrieve it because it was locked in the container.
  
  - (2) Officer Wiley kept his semiautomatic pistol locked in a hall closet along with his two hunting rifles. While Officer Wiley was away, an argument broke out between two family members. While in a fit of anger, one family member broke into the closet to retrieve the pistol. Because Officer Wiley stored the firearm unloaded and locked the ammunition separately in a different location in the house, the family member was not able to use the firearm.
-

# Chapter Synopsis

---

**Learning need** Peace officers must know and practice all procedures for the safe handling of all firearms while both on and off duty.

---

**Fundamental rules of firearms safety**  
[35.01.EO1] There are four fundamental rules of firearms safety that must be respected and obeyed at all times with no exceptions.

---

**Range safety guidelines**  
[35.01.EO2] A firing range consists of a firing line and targets. Officers are positioned on the firing line and fire at the targets.

---

**Proper firearms storage**  
[35.01.EO3] All firearms must be kept out of reach of children and immature or irresponsible adults.

---

# Workbook Learning Activities

---

## **Introduction**

To help you review and apply the material covered in this chapter, a selection of learning activities has been included. No answers are provided. However, by referring to the appropriate text, you should be able to prepare a response.

---

## **Activity questions**

1. What is an unintentional discharge? Some law enforcement professionals believe there is no such thing as an accidental discharge. What do you think? Explain your position.
  
  
  
  
  
  
  
  
  
  
2. Officers are pursuing an armed robbery suspect on foot. As the suspect passes a playground, he tosses what appears to be a firearm over the fence near a group of children. One officer stops pursuit to retrieve and secure the firearm. Describe the actions this officer should take.

---

*Continued on next page*

## Workbook Learning Activities, Continued

---

**Activity  
questions  
(continued)**

3. Consider your current living situation. Explain precisely how you would safely store a firearm in your home today. Identify any special precautions you would take to prevent discovery by children, theft, etc.
  
  
  
  
  
  
  
  
  
  
4. A neighbor hands a newly purchased semiautomatic pistol to an officer and tells her to “check it out.” What is the first action the officer should take according to the rules of firearms safety? What else should the officer do while examining the firearm?

---

*Continued on next page*



## Workbook Learning Activities, Continued

---

**Activity  
questions**  
(continued)

5. An officer is firing a friend's semiautomatic pistol at a local firing range. After firing one magazine of ammunition, the officer reloads. The officer squeezes the trigger when the command is again given to fire, but nothing happens. What should the officer do and why?

6. When is the improper storage of a firearm considered a felony? Give an example.

---

*Continued on next page*

## **Workbook Learning Activities, Continued**

---

**Student notes**

# Chapter 2

## Basic Firearms Operation

### Overview

---

**Learning need** Peace officers must know the workings, the capabilities, and limitations of firearms in order to operate them safely and effectively.

---

**Learning objectives** The chart below identifies the student learning objectives for this chapter.

<b>After completing study of this chapter, the student will be able to:</b>	<b>E.O. Code</b>
<ul style="list-style-type: none"><li>• Describe the basic information about a semiautomatic pistol and magazine, including:<ul style="list-style-type: none"><li>- Primary components and their functions</li><li>- Steps for loading/unloading</li><li>- Steps for rendering the semiautomatic pistol safe</li></ul></li></ul>	35.02.EO1 35.02.EO2 35.02.EO3
<ul style="list-style-type: none"><li>• Describe the cycle of operation that takes place with each single pull of a semiautomatic pistol trigger</li></ul>	35.02.EO4
<ul style="list-style-type: none"><li>• Describe the basic information about a revolver including:<ul style="list-style-type: none"><li>- Primary components and their functions</li><li>- Steps for loading/unloading</li><li>- Steps for rendering the revolver safe</li></ul></li></ul>	35.02.EO5 35.02.EO6 35.02.EO7
<ul style="list-style-type: none"><li>• Describe the basic information about shotguns including:<ul style="list-style-type: none"><li>- Advantages and limitations</li><li>- Primary components and their functions</li><li>- Steps for loading/unloading</li><li>- Steps for rendering the shotgun safe</li></ul></li></ul>	35.02.EO8 35.02.EO9 35.02.EO10 35.02.EO11

---

*Continued on next page*

## Overview, Continued

---

**In this chapter** This chapter focuses on the basic nomenclature and operation of firearms. Refer to the following chart for specific topics.

<b>Topic</b>	<b>See Page</b>
Semiautomatic Pistols and Magazines	2-3
Revolvers	2-14
Shotguns	2-20
Chapter Synopsis	2-28
Workbook Learning Activities	2-31

---

# Semiautomatic Pistols and Magazines

[35.02.EO1, 35.02.EO2, 35.02.EO3, 35.02.EO4]

---

## Introduction

Peace officers' firearms are one of the most important pieces of safety equipment used in defense of themselves and others. The most commonly issued firearm is the semiautomatic pistol. A **semiautomatic firearm** is a firearm that features a magazine which holds cartridges that self-load into the firing chamber automatically.

---

## Automatic vs. semiautomatic

An **automatic firearm** will load and fire automatically and continuously with a *single pull of the trigger* until the magazine is empty (e.g., machine guns).

A semiautomatic firearm will load and fire only *one cartridge* automatically with a *single pull of the trigger* (e.g., semiautomatic pistols).

NOTE: Some firearms can be set to operate in either an automatic or semiautomatic mode.

---

## Semiautomatic pistols used by peace officers

There are many different makes and models of semiautomatic pistols. Each requires extensive training to use safely. The characteristics and location of key parts may differ substantially among manufacturers. This chapter deals with the basic nomenclature and operation that is common to all types of semiautomatic pistols.

NOTE: Officers are responsible for knowing the **nomenclature and operation** of the specific make and model of semiautomatic pistol they are issued.

---

*Continued on next page*

## Semiautomatic Pistols and Magazines, Continued

---

**Basic  
nomenclature:  
exterior**

The following table identifies the basic exterior components of a semiautomatic pistol:

<b>Exterior Component</b>	<b>Description/Function</b>
<b>Hammer</b>	<ul style="list-style-type: none"><li>• Part of the handgun that drives the <b>firing pin</b> forward</li></ul>
<b>Trigger</b>	<ul style="list-style-type: none"><li>• Device which, when pulled, releases the hammer/striker</li></ul>
<b>Trigger Guard</b>	<ul style="list-style-type: none"><li>• Device which circles the trigger</li></ul>
<b>Barrel</b>	<ul style="list-style-type: none"><li>• Tube through which the bullet is discharged</li></ul>
<b>Muzzle</b>	<ul style="list-style-type: none"><li>• End of the firearm from which the projectile emerges</li></ul>
<b>Slide</b>	<ul style="list-style-type: none"><li>• Top part of the firearm that contains the firing mechanism</li><li>• Ejects spent cartridge and cycles new cartridges</li></ul>
<b>Slide Lock</b>	<ul style="list-style-type: none"><li>• Locks the slide to the rear</li></ul>
<b>Safety</b>	<ul style="list-style-type: none"><li>• Device designed to prevent the firearm from firing</li></ul>
<b>Decocking Lever</b>	<ul style="list-style-type: none"><li>• Device on most semiautomatic pistols that is designed to safely lower the hammer and/or release the slide</li></ul>
<b>Sights</b>	<ul style="list-style-type: none"><li>• Devices used to aid in aiming the firearm</li></ul>
<b>Ejection Port</b>	<ul style="list-style-type: none"><li>• Location where spent cartridge is ejected from the handgun</li></ul>
<b>Grip</b>	<ul style="list-style-type: none"><li>• Portion of the firearm that is held in the hand</li></ul>
<b>Frame</b>	<ul style="list-style-type: none"><li>• Metal or polymer housing of the handgun below the slide</li></ul>
<b>Disassembly Lever</b>	<ul style="list-style-type: none"><li>• Lever that allows removal of slide from frame</li></ul>

---

*Continued on next page*

## Semiautomatic Pistols and Magazines, Continued

**Basic nomenclature: exterior**  
(continued)

Exterior Component	Description/Function
<b>Magazine Well</b>	<ul style="list-style-type: none"> <li>Opening at bottom of the grip where the magazine is inserted</li> </ul>
<b>Magazine Release</b>	<ul style="list-style-type: none"> <li>Mechanism that, when depressed, releases the magazine from the firearm</li> </ul>
<b>Tang</b>	<ul style="list-style-type: none"> <li>The curved tongue portion on the top of the backstrap</li> </ul>
<b>Backstrap</b>	<ul style="list-style-type: none"> <li>The back portion of the grip</li> </ul>

NOTE: A graphic illustration of the exterior of a semiautomatic pistol is provided in the *Supplementary Material* of this workbook.

**Basic nomenclature: interior**

Along with the outer parts, officers must become familiar with the inner working parts of their semiautomatic pistol. The following table identifies the basic interior components of a semiautomatic pistol.

Interior Component	Description/Function
<b>Barrel Rifling</b>	<ul style="list-style-type: none"> <li>Spiral grooves machined into the interior of the firearm's barrel which causes the bullet to spin when fired, giving it stability</li> </ul>
<b>Breech</b>	<ul style="list-style-type: none"> <li>Rear end of the barrel, including the chamber</li> </ul>
<b>Chamber</b>	<ul style="list-style-type: none"> <li>Inner portion of the barrel where the cartridge is seated</li> </ul>
<b>Firing Pin</b>	<ul style="list-style-type: none"> <li>Part of the handgun which strikes the primer of the cartridge</li> </ul>
<b>Ejector</b>	<ul style="list-style-type: none"> <li>Pushes the spent casing from the ejection port</li> </ul>

*Continued on next page*

## Semiautomatic Pistols and Magazines, Continued

**Basic nomenclature: interior**  
(continued)

<b>Interior Component</b>	<b>Description/Function</b>
<b>Recoil Spring and Guide</b>	<ul style="list-style-type: none"> <li>• Mechanism that returns the slide to the firing position</li> </ul>
<b><u>Extractor</u></b>	<ul style="list-style-type: none"> <li>• Device that pulls casings from the chamber</li> </ul>

NOTE: A graphic illustration of the interior of a semiautomatic pistol is provided in the *Supplementary Material* of this workbook.

**Basic nomenclature: magazine**

A **magazine** is a container that holds cartridges and fits inside the magazine well of a semiautomatic pistol. The following table identifies the basic components of a magazine to be used with a semiautomatic pistol:

<b>Magazine Component</b>	<b>Description/Function</b>
<b>Body</b>	<ul style="list-style-type: none"> <li>• Exterior casing holding the mechanism of the magazine</li> </ul>
<b>Follower</b>	<ul style="list-style-type: none"> <li>• Device that directly follows the rounds and is pushed up by the spring</li> </ul>
<b>Spring</b>	<ul style="list-style-type: none"> <li>• Provides the tension which forces rounds up the magazine</li> </ul>
<b>Feed Lips</b>	<ul style="list-style-type: none"> <li>• Portion of the magazine body which holds the rounds in the proper position</li> </ul>
<b><u>Floor Plate</u></b>	<ul style="list-style-type: none"> <li>• Internal device which holds the follower and spring in place</li> </ul>
<b><u>Base Plate</u></b>	<ul style="list-style-type: none"> <li>• External plate that holds in the contents of the magazine</li> </ul>

*Continued on next page*



## Semiautomatic Pistols and Magazines, Continued

---

### Basic nomenclature: magazine (continued)

NOTE: In some semiautomatic pistols, the magazine must be fully inserted before the firearm will cycle and fire.

NOTE: A graphic illustration of a magazine for a semiautomatic pistol is provided in the *Supplementary Material* of this workbook.

---

### Loading a magazine

Specific procedures for loading the magazine of a semiautomatic pistol may vary with the make and model of firearm. There are a number of basic principles for safely loading a magazine.

When loading a magazine, officers should:

- hold the magazine in their support (nonfiring) hand and handle the cartridges in their primary (firing) hand
  - repeat the process until the magazine is full
- 

### Loading a pistol

The specific procedures for loading a semiautomatic pistol will vary depending on the make and model of the firearm. There are a number of basic guidelines that are common for the safe loading for all semiautomatic pistols.

When loading a semiautomatic pistol, officers should follow the steps noted in the table below:

Step	Action
1	Follow all fundamental rules of firearms safety
2	Load the full magazine into the magazine well
3	Pull back and release on the slide to chamber a round

---

*Continued on next page*

## Semiautomatic Pistols and Magazines, Continued

---

### Unloading (clearing) a semiautomatic pistol

Unloading is a function normally performed prior to dry firing, cleaning, or storing the firearm. When a firearm has been completely emptied and rendered safe, that firearm has then been cleared.

The specific procedures for **clearing** a semiautomatic pistol will vary depending on the make and model of the firearm. There are a number of basic guidelines that are common for clearing all semiautomatic pistols. When clearing a semiautomatic, officers should follow the steps noted in the table below:

Step	Action
1	Follow all fundamental rules of firearms safety
2	Release and remove the magazine
3	Eject any cartridge that may still be in the pistol's chamber
4	Lock slide to the rear
5	Visually and physically verify that there is no round in the chamber

### Cycle of operation

With each single pull of the trigger of a loaded semiautomatic pistol, a cartridge is fired, the empty casing is ejected, the hammer is cocked, and a new cartridge is loaded from the magazine into the pistol's chamber. This entire process is called the **cycle of operation**.

*Continued on next page*

## Semiautomatic Pistols and Magazines, Continued

---

### Cycle of operation (continued)

The following describes the stages of the cycle of operation for a semiautomatic pistol.

Stage	Description
<b>Firing</b>	<ul style="list-style-type: none"><li>• As the <i>trigger</i> is pulled, the <i>hammer/striker</i> is released.</li><li>• The <i>hammer</i> moves forward striking the <i>firing pin</i></li><li>• The <i>firing pin</i> then strikes the primer, which in turn ignites the powder charge in the round</li><li>• The expanding gases from the burning powder force the projectile from the casing and down the barrel</li></ul>
<b>Unlocking</b>	<ul style="list-style-type: none"><li>• As the projectile is forced from the pistol, the casing is forced in the opposite direction</li><li>• This force moves the <i>slide</i> to the rear of the handgun</li></ul>
<b>Extracting</b>	<ul style="list-style-type: none"><li>• As the <i>slide</i> moves to the rear, the <b>extractor</b> pulls the casing out of the handgun's <i>chamber</i></li></ul>
<b>Ejecting</b>	<ul style="list-style-type: none"><li>• The casing is then deflected out of the <b>ejection port</b></li></ul>
<b>Cocking</b>	<ul style="list-style-type: none"><li>• When the <i>slide</i> completes its movement to the rear, the hammer/striker is cocked</li></ul>
<b>Feeding</b>	<ul style="list-style-type: none"><li>• The <i>recoil spring</i> begins to push the <i>slide</i> forward in the firing position</li><li>• When the <i>slide</i> moves forward again, the next round is taken from the top of the magazine</li></ul>

---

*Continued on next page*

## Semiautomatic Pistols and Magazines, Continued

---

### Cycle of operation (continued)

Stage	Description
<b>Chambering</b>	<ul style="list-style-type: none"><li>• The force of the spring inside the magazine pushes the next round from the top of the magazine into the <i>chamber</i></li></ul>
<b>Locking</b>	<ul style="list-style-type: none"><li>• The <i>recoil spring</i> forces the slide all the way into the forward position, locking the <i>slide</i> in place.</li><li>• The pistol is then ready to fire, beginning the cycle once again</li></ul>

---

### Action

The **action** of a firearm refers to the assembly of functional parts which move when the trigger is pulled, causing the firearm to fire. The process of operating the action to chamber a round is also referred to as **racking** the firearm.

The action of a semiautomatic pistol contains the parts of the pistol that:

- cocks the hammer/striker
  - moves the cartridge into the chamber
  - releases the hammer/striker to fire the cartridge
- 

*Continued on next page*

## Semiautomatic Pistols and Magazines, Continued

---

### **Battery**

When the action of a firearm is in the firing position, it is referred to as being **in battery**. If any portion of the action is out of the firing position, it is **out of battery**. When a firearm is out of battery, it will not function.

Example:           A semiautomatic pistol is out of battery when the slide is retracted and not in the firing position. When the slide is fully forward and locked into place, the pistol is in battery.

---

### **Double-action and single-action**

Many semiautomatic pistols can function in two modes: double-action and single-action.

**Double-action** mode is a method of shooting where pulling the trigger begins a complete cycle of operation to fire the firearm.

**Single-action** mode is a method of shooting where the hammer is cocked back before the firearm can be fired.

---

### **Decocking**

Many semiautomatic pistols remain cocked after they have been fired until they have been decocked by the officer. **Decocking** releases the hammer to its forward position and returns the firearm to a double-action mode.

---

*Continued on next page*

## Semiautomatic Pistols and Magazines, Continued

---

### Manual decocking

Another method of decocking a firearm is to manually lower the hammer. In order to manually decock a semiautomatic pistol, officers should follow the steps noted in the following table.

Step	Action
1	Follow all fundamental rules of firearms safety
2	Place the thumb of the primary hand on the hammer
3	Press the trigger while maintaining control of the hammer
4	Once the hammer has been released, remove finger from the trigger
5	Gently guide the hammer forward out of a cocked position

NOTE: In some semiautomatics this is not a recommended procedure for decocking.

---

*Continued on next page*

## Semiautomatic Pistols and Magazines, Continued

---

**Student notes** During class, instructors will demonstrate the proper procedures for loading, clearing, and conducting a chamber check for the specific model of handgun that has been issued to each student.

# Revolvers

[35.02.EO5, 35.02.EO6, 35.02.EO7]

---

## Introduction

A **revolver** is a firearm equipped with a revolving cylinder that can contain several cartridges. It can be fired repeatedly without being reloaded until the cylinder is empty.

---

## Revolvers used by law enforcement

There are many different makes and models of revolvers. The characteristics and location of key parts may differ substantially among manufacturers. This chapter deals with the basic nomenclature and operation that is common for all types of revolvers.

NOTE: Officers are responsible for knowing the specific nomenclature and operation of the particular make and model of revolver they carry.

---

## Basic nomenclature

The following table identifies the basic exterior components of a revolver:

Component	Description/Function
Frame	<ul style="list-style-type: none"><li>Main part of the revolver which contains the action, barrel, trigger, cylinder, and grip</li></ul>
Cylinder and Chambers	<ul style="list-style-type: none"><li>Round device which contains a series of holes referred to as chambers</li><li>Each chamber holds a single cartridge</li><li>The cylinder rotates to place each chamber into a firing position</li></ul>
Cylinder Release	<ul style="list-style-type: none"><li>Latch which allows the cylinder to be opened out from the frame</li></ul>

---

*Continued on next page*



## Revolvers, Continued

Basic  
nomenclature  
(continued)

Component	Description/Function
<b>Extractor/ Ejector Rod</b>	<ul style="list-style-type: none"><li>Removes the cartridges from the cylinder when the cylinder is open</li></ul>
<b>Barrel</b>	<ul style="list-style-type: none"><li>Tube through which the bullet is discharged</li></ul>
<b>Barrel Rifling</b>	<ul style="list-style-type: none"><li>Spiral grooves machined into the interior of the firearm's barrel, which causes the bullet to spin when fired, giving it stability</li></ul>
<b>Muzzle</b>	<ul style="list-style-type: none"><li>The end of the firearm from which the projectile emerges</li></ul>
<b>Sights</b>	<ul style="list-style-type: none"><li>Devices used to aid in aiming the firearm</li></ul>
<b>Trigger</b>	<ul style="list-style-type: none"><li>Device which, when pulled, activates the hammer</li></ul>
<b>Trigger Guard</b>	<ul style="list-style-type: none"><li>Device which circles the trigger</li></ul>
<b>Hammer</b>	<ul style="list-style-type: none"><li>Device that drives the firing pin forward</li></ul>
<b>Firing Pin</b>	<ul style="list-style-type: none"><li>Device which strikes the primer of the cartridge</li></ul>
<b>Grip</b>	<ul style="list-style-type: none"><li>Portion of the firearm that is held in the hand</li></ul>
<b>Back Strap</b>	<ul style="list-style-type: none"><li>Back of the grip that the palm of the primary hand fits around</li></ul>

NOTE: A graphic illustration of a revolver is provided in the Supplementary Material of this workbook.

*Continued on next page*

## Revolvers, Continued

---

### Loading a revolver

There are a number of basic guidelines that are common for the safe loading for all revolvers. When loading a revolver, officers should follow the steps noted in the table below.

Step	Action
1	Follow all fundamental rules of firearms safety
2	Open the cylinder
3	Place a single round in each chamber of the cylinder, one at a time
4	Visually and physically inspect each chamber to make sure it contains a cartridge
5	Close the cylinder and make sure it is locked in place

---

### Speedloaders

Many revolvers can also be loaded by using a **speedloader**. When loading a revolver with a speedloader, the entire cylinder is filled with cartridges in one step. Extra speedloaders can be kept in the officer's duty belt for easy access.

---

*Continued on next page*

## Revolvers, Continued

---

### Unloading (clearing) a revolver

To render a revolver safe, it must first be cleared. When unloading a revolver, officers should follow the steps noted in the table below.

Step	Action
1	Follow all fundamental rules of firearms safety.
2	Open the cylinder.
3	While holding the revolver muzzle up, push the extractor/ejector rod down to release cartridges or spent casings from each chamber of the cylinder.
4	Visually and physically inspect <i>each chamber</i> in the cylinder to verify that it is empty.

---

### Revolver chamber check

Just as with other firearms, officers need to conduct a visual and physical verification of the condition of the firearm to determine if a round is in any of the chambers of the cylinder.

When conducting a chamber check of a revolver, officers should follow the steps noted in the following table.

Step	Action
1	Follow all fundamental rules of firearms safety.
2	Open the cylinder.
3	Visually and physically examine each chamber to determine if it contains a round. (In low light conditions, this can be done physically.)
4	Close the cylinder and make sure it is locked in place.

---

*Continued on next page*

## Revolvers, Continued

---

### Rendering a revolver safe

Officers must always remember that a revolver has been rendered safe *only* when:

- all rounds have been removed from *each chamber* of the cylinder
  - the cylinder is left open
- 

### Action

The action on a revolver contains the moving parts which:

- cocks the hammer
- rotates and line up the cylinder
- releases the hammer causing the revolver to fire

Like semiautomatic pistols, many revolvers can function in single-action and double-action modes.

NOTE: Revolvers in single action mode should be rendered safe per academy/agency policy.

---

## Revolvers, Continued

---

**Student notes** During class, instructors will demonstrate the proper procedures for loading, clearing, and conducting a chamber check for the specific model of revolver that has been issued to each student.

# Shotguns

[35.02.EO8, 35.02.EO9, 35.02.EO10, 35.02.EO11]

---

## Introduction

A **shotgun** is a smooth-bored firearm designed to be fired from the shoulder with two hands. Shotguns are primarily intended for firing multiple projectiles at one time.

---

## Advantages

The law enforcement shotgun is designed for a different mission than a handgun. It can be utilized in situations when officers have knowledge or the reasonable expectation that they are likely to encounter an armed suspect.

There are a number of advantages to peace officers' use of shotguns in certain situations. These advantages are identified in the following table:

<b>Advantage</b>	<b>Explanation</b>
<b>Can be used in a variety of situations</b>	<ul style="list-style-type: none"><li>• It can be used as a rifle, a shotgun, or as a chemical agent delivery device</li></ul>
<b>Multiple Projectiles</b>	<ul style="list-style-type: none"><li>• It has the potential to fire multiple projectiles instead of one with every pull of the trigger</li><li>• There is greater potential to cause more severe trauma or damage to human tissue</li></ul>
<b>Variety of Loads</b>	<ul style="list-style-type: none"><li>• Shotgun shells can contain slugs, pellets, and even birdshot</li><li>• When tactically appropriate (where pellet spread is not desirable) a rifled slug may be used</li></ul>
<b>Psychological Value</b>	<ul style="list-style-type: none"><li>• Often the appearance of a peace officer with a shotgun or the sound of a shotgun being racked may provide enough of a deterrent to force a suspect to submit to the officer's authority</li></ul>

NOTE: Additional information regarding shotgun ammunition can be found in a later chapter of this workbook.

---

*Continued on next page*

## Shotguns, Continued

---

### Limitations

Officers should be aware that there are limitations to the use of a shotgun. These limitations are identified in the following table.

<b>Limitation</b>	<b>Explanation</b>
<b>Portability</b>	<ul style="list-style-type: none"><li>• When moving in tight areas, a large shotgun may prove to be a hindrance</li></ul>
<b>Accessibility</b>	<ul style="list-style-type: none"><li>• Shotguns are not carried on an officer's person as handguns are</li></ul>
<b>Shot Pattern</b>	<ul style="list-style-type: none"><li>• When using multiple projectiles, the pellets spread out into a continuing greater area as they move toward the target</li><li>• At greater distances, the shot pattern may be so large that it proves to be ineffective or actually misses the target</li></ul>
<b>Collateral Damage</b>	<ul style="list-style-type: none"><li>• Due to the spread of projectiles, there may be greater risk to bystanders or nearby property</li></ul>
<b>Altercations</b>	<ul style="list-style-type: none"><li>• Difficult to secure during a physical altercation</li></ul>

### Shotguns used by law enforcement

There are many different makes and models of shotguns. The characteristics and location of key parts may differ substantially among manufacturers. This chapter deals with the basic nomenclature and operation that is common for all types of shotguns.

NOTE: Officers are responsible for knowing the *specific nomenclature and operation* of the particular make and model of shotgun they utilize.

---

*Continued on next page*

## Shotguns, Continued

---

### Basic nomenclature

The following table identifies the basic exterior components of a shotgun.

<b>Component</b>	<b>Description/Function</b>
<b>Trigger</b>	<ul style="list-style-type: none"><li>• Device which, when pulled, activates the hammer</li></ul>
<b>Trigger Guard</b>	<ul style="list-style-type: none"><li>• Device which circles the trigger</li></ul>
<b>Barrel</b>	<ul style="list-style-type: none"><li>• Tube through which the projectile(s) is discharged</li></ul>
<b>Muzzle</b>	<ul style="list-style-type: none"><li>• The end of the shotgun from which the bullet(s) emerges</li></ul>
<b>Loading Port</b>	<ul style="list-style-type: none"><li>• Opening where cartridges are loaded into the shotgun</li></ul>
<b>Magazine Tube</b>	<ul style="list-style-type: none"><li>• Portion of the shotgun that holds ammunition</li></ul>
<b>Ejection Port</b>	<ul style="list-style-type: none"><li>• Opening where spent casings are expelled from the shotgun</li></ul>
<b>Receiver/ Frame</b>	<ul style="list-style-type: none"><li>• Housing for firing mechanism</li></ul>
<b>Grip</b>	<ul style="list-style-type: none"><li>• Portion of the stock at the rear of the receiver where the officer's primary hand grasps the shotgun in all searching and firing positions</li></ul>
<b>Stock</b>	<ul style="list-style-type: none"><li>• Portion of the shotgun attached to the frame</li><li>• Used to assist in holding the shotgun</li></ul>
<b>Butt</b>	<ul style="list-style-type: none"><li>• Rear of the stock</li></ul>
<b>Safety</b>	<ul style="list-style-type: none"><li>• Mechanism which locks or blocks the trigger, hammer, or other part of the action so that the shotgun cannot discharge</li></ul>

---

*Continued on next page*



## Shotguns, Continued

### Basic nomenclature (continued)

---

Component	Description/Function
<b>Action Release</b>	<ul style="list-style-type: none"><li>• Device on the trigger guard that unlocks the shotgun's slide handle allowing the slide handle to open and close the action</li></ul>
<b>Sights</b>	<ul style="list-style-type: none"><li>• Devices used to aid in aiming the shotgun</li></ul>
<b>Fore End</b>	<ul style="list-style-type: none"><li>• Operates the action to chamber a shell</li></ul>

NOTE: A graphic illustration of a shotgun is provided in the Supplementary Material of this workbook.

---

### Loading the magazine tube

Loading and unloading procedures will vary depending on the make and model of shotgun used. There are a number of basic steps that are common with all shotguns.

When loading the magazine tube of a shotgun, officers should follow the basic steps noted in the following table.

Step	Description
<b>1</b>	Follow all fundamental rules of firearms safety
<b>2</b>	Open the action and visually and physically inspect the chamber to make sure it does not contain a shell
<b>3</b>	Close the action and make sure it is locked in place
<b>4</b>	Load shells one at a time into the magazine tube until the tube is filled to capacity

NOTE: A shotgun should always be placed into a patrol vehicle following all fundamental rules of firearms safety.

---

*Continued on next page*

## Shotguns, Continued

---

### **Chambering a shell**

Once the magazine tube has been properly loaded, officers can chamber a round by pulling back or pumping the fore-end of the shotgun. This action is referred to as racking the shotgun.

When loading the magazine tube of a shotgun, officers should follow the basic steps noted in the following table.

<b>Step</b>	<b>Description</b>
<b>1</b>	Follow all fundamental rules of firearms safety
<b>2</b>	Rack the action to chamber a round
<b>3</b>	Keep weapon pointed in a safe direction (downrange)

---

### **Unloading (clearing) a shotgun**

The specific procedures for clearing a shotgun will vary depending on the make and model of the firearm. The basic steps for clearing all shotguns are noted in the following table.

<b>Step</b>	<b>Description</b>
<b>1</b>	Follow all fundamental rules of firearms safety
<b>2</b>	Engage the action release and open the chamber
<b>3</b>	Remove any round that may be in the chamber
<b>4</b>	Remove all rounds from the magazine tube
<b>5</b>	Visually and physically inspect the chamber, magazine tube, and loading port to verify that no shells remain in the shotgun

---

*Continued on next page*

## Shotguns, Continued

---

### Rendering the shotgun safe

Officers must always remember that a shotgun has been rendered safe **only** when:

- the safety is on
  - all rounds are removed from the chamber and magazine tube
  - the chamber and magazine tube have been visually and physically inspected to verify the shotgun is empty
  - the action is left open
- 

### Safety checks

At minimum, officers should conduct a safety check of their shotguns before going on duty and any time there is a question or concern about the mechanical parts of the shotgun. When conducting a safety check, officers should follow the basic steps noted in the table below. In order to remember the steps involved in a safety check, officers can refer to the acronym “**BEEF**.”

Step	Description
1	Follow all fundamental rules of firearms safety
2	Make sure the safety is on
3	Engage the action release and open the chamber
4	Visually and physically inspect the barrel, chamber, magazine tube, and loading port to verify there are no shells in the shotgun

---

*Continued on next page*

## Shotguns, Continued

### Safety checks (continued)

Step	Description	
5	With the shotgun empty, check the following components to ensure they are working properly.	
	Barrel	Check for obstructions or damage
	Ejector	Make sure the shell ejector is firmly attached and properly working
	Extractor	Inspect the shell extractor hook to ensure that it is in place and is squared, not rounded
	Firing pin	By pulling the trigger, check to make sure the firing pin is operating properly

### Pump vs. semiautomatic

Shotguns actions have two primary modes of operation. They can be operated manually by racking or pumping the action, or they can have semiautomatic actions. The following table identifies the characteristics of each.

Pump Shotguns	Semiautomatic Shotguns
<ul style="list-style-type: none"> <li>Operated by working the fore end to load shells into the chamber</li> <li>Most makes and models are generally similar</li> <li>Usually holds four or more rounds</li> </ul>	<ul style="list-style-type: none"> <li>Shells are automatically loaded into the chamber</li> <li>Semiautomatic action may lessen recoil when fired</li> <li>Usually holds four or more rounds</li> </ul>

*Continued on next page*

## Shotguns, Continued

---

**Student notes** During class, instructors will demonstrate the proper procedures for loading, clearing, and conducting a safety check for specific models of shotguns used by peace officers.

# Chapter Synopsis

---

**Learning need** Peace officers must know the workings, the capabilities, and limitations of firearms in order to operate them safely and effectively.

---

**Semiautomatic pistols and magazines: primary components**  
[35.02.EO1] A semiautomatic pistol is a firearm that features a magazine which holds cartridges that self-load into the firing chamber automatically.

---

**Semiautomatic pistols and magazines: loading/unloading**  
[35.02.EO2] The specific procedures for loading and unloading a semiautomatic pistol will vary depending on the make and model of the handgun.

---

**Rendering a semiautomatic pistol safe**  
[35.02.EO3] A semiautomatic pistol has been rendered safe *only* when the:

- magazine has been removed from the pistol
- slide is locked open
- unspent cartridges have been emptied from the chamber
- pistol has been checked to verify that there is no round in the chamber

---

**Semiautomatic pistols cycle of operation**  
[35.02.EO4] There are eight continuous stages that take place with each single pull of a loaded semiautomatic pistol.

---

*Continued on next page*

## Chapter Synopsis, Continued

---

**Revolvers:  
primary  
components  
[35.02.EO5]**

The primary components of a revolver include the frame, cylinder and chambers, cylinder release, extractor/ejector rod, barrel, barrel rifling, muzzle, sights, trigger, trigger guard, hammer, firing pin, grip and back strap.

---

**Revolvers:  
loading/  
unloading  
[35.02.EO6]**

The specific procedures for loading and unloading a revolver will vary depending on the make and model of the firearm.

---

**Rendering a  
revolver safe  
[35.02.EO7]**

Officers must always remember that a revolver has been *rendered safe only* when:

- all rounds have been removed from *each chamber* of the cylinder
  - the cylinder is left open
- 

**Shotguns:  
advantages/  
disadvantages  
[35.02.EO8]**

There are a number of advantages to peace officers' use of shotguns in certain situations: they can be used in various situations, can fire multiple projectiles, use of a variety of loads and they have a psychological value.

---

**Shotguns:  
primary  
components  
[35.02.EO9]**

There are many different makes and models of shotguns. The characteristics and location of key parts may differ substantially among manufacturers.

---

*Continued on next page*

## Chapter Synopsis, Continued

---

**Shotguns:  
loading/  
unloading  
[35.02.EO10]**

The specific procedures for loading and unloading a shotgun will vary depending on the make and model of the shotgun.

---

**Rendering the  
shotgun safe  
[35.02.EO11]**

Officers must always remember that a shotgun has been rendered safe **only** when:

- the safety is on
  - all rounds are removed from the chamber and magazine port
  - the chamber and magazine tube have been visually and physically
  - inspected to verify the shotgun is empty
  - the action is left open
-



# Workbook Learning Activities

---

## **Introduction**

To help you review and apply the material covered in this chapter, a selection of learning activities has been included. No answers are provided. However, by referring to the appropriate text, you should be able to prepare a response.

---

## **Activity Questions**

1. Using your own words, describe what takes place for each stage of the cycle of operation for a semiautomatic pistol from the time the trigger is pulled.

2. List five key differences between a revolver and a semiautomatic pistol.

---

*Continued on next page*



## Workbook Learning Activities, Continued

---

**Activity  
Questions**  
(continued)

5. What is a chamber check and when should it be conducted? Describe, step-by-step, how to conduct a chamber check on the firearm you have been issued.
  
  
  
  
  
  
  
  
  
  
6. Without looking back in the chapter or the chapter synopsis, identify the exterior and interior components of the semiautomatic pistol you have been issued.

---

*Continued on next page*

## **Workbook Learning Activities, Continued**

---

**Student notes**

# Chapter 3

## Firearms Ammunition

### Overview

---

**Learning need** Peace officers must know the capabilities and limitations of the ammunition they use in their firearms to operate them safely and effectively.

---

**Learning objectives** The chart below identifies the student learning objectives for this chapter.

<b>After completing study of this chapter, the student will be able to:</b>	<b>E.O. Code</b>
<ul style="list-style-type: none"><li>• State the guidelines for the safe handling of ammunition</li></ul>	35.03.EO1
<ul style="list-style-type: none"><li>• Describe the primary components of firearm cartridges</li></ul>	35.03.EO2
<ul style="list-style-type: none"><li>• Explain the chain of events that takes place when a projectile is discharged from a cartridge</li></ul>	35.03.EO3
<ul style="list-style-type: none"><li>• Describe the primary components of a shotgun shell</li></ul>	35.03.EO4
<ul style="list-style-type: none"><li>• Define shot pattern as it relates to shotgun shells</li></ul>	35.03.EO5
<ul style="list-style-type: none"><li>• Explain the correlation to the distance traveled by the shot and the size of the shot pattern</li></ul>	35.03.EO6
<ul style="list-style-type: none"><li>• Describe the three ways shot placement can stop a threat to include:<ul style="list-style-type: none"><li>- Central nervous system</li><li>- Critical blood loss</li><li>- Psychological</li></ul></li></ul>	35.03.EO7

---

*Continued on next page*

## Overview, Continued

---

**In this chapter** This chapter focuses on ammunition that may be used in handguns and shotguns. Refer to the following chart for specific topics.

<b>Topic</b>	<b>See Page</b>
Ammunition Safety	3-3
Cartridge Ammunition	3-6
Shotgun Ammunition	3-10
Wound Ballistics	3-14
Chapter Synopsis	3-16
Workbook Learning Activities	3-18

---

# Ammunition Safety

[35.03.EO1]

---

## Introduction

**Ammunition** is the general term applied to cartridges and shotgun shells used as firearm projectiles. The performance of a firearm is closely related to the ammunition that is used.

---

## Ammunition cautions

Ammunition should be handled with care and respect at all times. Even ammunition that is being stored away from firearms can be dangerous.

Ammunition can go off if it is:

- dropped on a hard surface
- struck with enough force to indent the primer at the base of the cartridge
- placed in contact with electrical current
- exposed to extreme heat

NOTE: Ammunition can still fire even after being immersed in water for long periods of time.

---

*Continued on next page*

## Ammunition Safety, Continued

---

### Safety guidelines

Each firearm has been designed for ammunition of a specific type and caliber. Safety is as critically important when handling ammunition as it is when handling any firearm. The following table identifies safety guidelines for handling any type of ammunition:

Safety Guideline	Explanation
Treat every round as though it were fully charged and capable of discharging	<ul style="list-style-type: none"><li>• All ammunition is potentially dangerous and should be handled with caution</li></ul>
Use only the type and caliber of ammunition specifically recommended by the firearm's manufacturer	<ul style="list-style-type: none"><li>• Improper ammunition can lead to malfunctions or hinder accuracy</li></ul>
Never fire at a threat you do not intend to hit	<ul style="list-style-type: none"><li>• Even a <b>blank shell</b> fired at close range can strike a vulnerable area and kill</li></ul>
Avoid dropping live rounds or hitting them with any object	<ul style="list-style-type: none"><li>• When any sharp object strikes the primer cap with sufficient force, the round can fire</li></ul>
Learn the sound and feel of a good firing, and know what to do when a round misfires	<ul style="list-style-type: none"><li>• Occasionally a round that looks perfect will fail to fire or fire with insufficient force to propel the bullet out of the barrel</li></ul>

*Continued on next page*



## Ammunition Safety, Continued

---

**Safety  
guidelines**  
(continued)

Safety Guideline	Explanation
All ammunition should be replaced on a regular basis	<ul style="list-style-type: none"><li>• Officers should refer to manufacturing recommendations regarding how often ammunition should be replaced</li></ul>
Never use ammunition where the pressure levels exceed industry standards for the firearm being used	<ul style="list-style-type: none"><li>• Improper ammunition can cause excessive pressure that can damage or even blow up the firearm</li><li>• Manufacturer's warranties, express or implied, may be voided if ammunition with greater chamber pressure than what is recommended is used</li></ul>

NOTE: There are two categories for enhanced chamber pressure that are related to a cartridge's powder charge: +P and +P+. +P ammunition has 15% more chamber pressure while +P+ has 30% more chamber pressure. (Some alloy framed handguns should not utilize +P or +P+ ammunition.)

---

# Cartridge Ammunition

[35.03.EO2, 35.03.EO3]

---

## Introduction

A **cartridge** is a self-contained unit which includes a projectile and propellant capable of firing the projectile through the barrel of a firearm. A bullet is the projectile that is expelled from the cartridge. A single cartridge is also called a **round**.

---

## Firearm cartridges

The following table identifies the four basic components of all cartridges used in firearms.

Cartridge Components	Description/Function
<b>Primer</b>	<ul style="list-style-type: none"><li>• Detonation charge contained in the base of the cartridge</li></ul>
<b>Powder Charge</b>	<ul style="list-style-type: none"><li>• Gun powder which burns when detonated by the primer</li></ul>
<b>Bullet</b>	<ul style="list-style-type: none"><li>• Actual projectile that is expelled from the firearm toward the intended threat</li></ul>
<b>Cartridge Case</b>	<ul style="list-style-type: none"><li>• Outer container that holds the primer, powder charge, and projectile</li><li>• Usually made of brass or other metal</li></ul>
<b>Blank Shell</b>	<ul style="list-style-type: none"><li>• A cartridge which contains an explosive charge but without a bullet</li></ul>

NOTE: A graphic illustration of a firearm cartridge is provided in the *Supplementary Material* of this workbook. (See page S-7)

---

*Continued on next page*

## Cartridge Ammunition, Continued

---

### Firing chain of events

The following table describes the chain of events that take place when a bullet is fired from a firearm.

Event	Action
<b>Primer Detonated</b>	<ul style="list-style-type: none"><li>• When struck by the firing pin/striker, the pressure sensitive compound of the primer explodes</li><li>• The compound changes structure and disintegrates completely</li><li>• Heat is generated in the explosion</li></ul>
<b>Powder Ignited</b>	<ul style="list-style-type: none"><li>• Powder is ignited by the heat generated from the primer</li><li>• The burning powder creates great quantities of gas which expand very rapidly</li><li>• Pressure builds in the chamber and barrel from the expanding gasses</li></ul>
<b>Bullet Expelled</b>	<ul style="list-style-type: none"><li>• The expanding gasses force the bullet from the firearm's barrel</li></ul>

NOTE: The partial burning of a powder charge in a cartridge can result in insufficient force to propel the bullet out of the firearm. This partial explosion is referred to as a **squib load**. If a squib load is encountered, the individual should immediately cease firing, utilize a secondary firearm, and later seek assistance.

---

*Continued on next page*

## Cartridge Ammunition, Continued

---

### Caliber

Each firearm has been designed for ammunition of a specific type and **caliber**. Caliber refers to the diameter of a projectile. It can be measured in hundredths of an inch or in millimeters.

Examples:           - A .38 caliber bullet is .38 inches in diameter  
                          - A 9 MM bullet is 9 millimeters in diameter

NOTE:           Caliber is also used to describe the internal diameter of a firearm's barrel.

---

### Grain

**Grain** refers to the weight of a projectile.

Examples:           - A .38 caliber bullet weighs 110-180 grains  
                          - A 9 MM bullet weighs 115-147 grains

---

### Types of bullets

Bullets come in many different shapes and constructions. The three most common are noted in the following table.

Type	Description of Shape
Round Nose	• Tip of the bullet narrows to a rounded end
Hollow Point	• Tip of the bullet is concave in the center
Truncated	• Tip of the bullet narrows to a flat end

---

*Continued on next page*

## Cartridge Ammunition, Continued

---

### Bullet jackets

A **jacket** is a metal envelope that encloses or partially encloses the bullet within a cartridge. Round nose, hollow point, and truncated bullets may have the following types of jackets.

Jacket Type	Description	Characteristics
<b>Full Metal Jacket</b>	The entire bullet is completely enclosed by the jacket	<ul style="list-style-type: none"><li>• Less expansion and fragmentation upon impact</li><li>• Greater penetration</li></ul>
<b>Semi-Jacket</b>	Only the rear portion of the bullet is enclosed by the jacket	<ul style="list-style-type: none"><li>• Greater expansion and fragmentation upon impact</li></ul>
<b>No Jacket</b>	No portion of the bullet is enclosed	<ul style="list-style-type: none"><li>• Lead bullet</li></ul>

---

# Shotgun Ammunition

[35.03.EO4, 35.03.EO5, 35.03.EO6]

---

## Introduction

A single round used in a shotgun is referred to as a **shell**. A shotgun shell can contain single or multiple projectiles. The projectiles (referred to as **shot**) contained in the shell are often referred to as the **load**.

---

## Shotgun shells

The following table identifies the primary components of a shotgun shell:

Shell Component	Description
<b>Primer</b>	<ul style="list-style-type: none"><li>• Detonation charge contained in the base of the shotgun shell</li><li>• Ignites the powder charge</li></ul>
<b>Powder Charge</b>	<ul style="list-style-type: none"><li>• Gun powder which burns when detonated by the primer</li></ul>
<b>Wad</b>	<ul style="list-style-type: none"><li>• A plastic, fiber, or paper filler material used to separate the powder charge from the shot</li></ul>
<b>Load</b>	<ul style="list-style-type: none"><li>• Projectile(s) fired from a single shell toward the intended threat</li></ul>
<b>Shell Case</b>	<ul style="list-style-type: none"><li>• Outer container that holds the primer, powder charge, wad, and shot</li><li>• May be composed of metal, plastic, or paper, with a metal base</li></ul>

NOTE: A graphic illustration of a shotgun shell is provided in the Supplementary Material of this workbook.

---

*Continued on next page*

## Shotgun Ammunition, Continued

---

### **Buckshot**

The largest and most commonly used shot, **buckshot**, got its name from its original purpose -- killing deer. The most common size of buckshot used for law enforcement purposes is No. 00 *buckshot*.

Many law enforcement agencies are utilizing alternative loads such as No. 4 or No. 1 buckshot. The following table compares the different sizes of buckshot.

<b>Type</b>	<b>Diameter of Each Pellet</b>	<b>Number of Projectiles/Shell</b>
No. 4 buckshot	.24 inch	27-41
No. 3 buckshot	.25 inch	20-24
No. 1 buckshot	.30 inch	12-24
No. 0 buckshot	.32 inch	12
No. 00 buckshot	.33 inch	9-18

---

### **Shot penetration**

Although the multiple projectile load of a shotgun shell penetrates tissue well, it is less effective at penetrating other substances. Buckshot may not effectively penetrate glass, cars, or walls that officers may encounter in tactical situations.

---

*Continued on next page*

## Shotgun Ammunition, Continued

---

### Shot pattern

Shot travels down the barrel of the shotgun in a tight group. As the pellets exit the muzzle, they begin to spread apart forming what is referred to as a shot pattern. A **shot pattern** is the diameter of a circle in which the shot will fit.

The shot pattern will increase in size as the shot travels toward the threat. Test results indicate that the shot spread for No. 00 buckshot is approximately *one inch for each yard of distance*.

<b>At:</b>	<b>Shotgun pellets can spread approximately:</b>
10 yards	10 inches.
20 yards	20 inches.
30 yards	30 inches.

NOTE: In excess of 30 yards, the shot pattern begins to deteriorate and the formula noted above no longer applies.

---

*Continued on next page*



## Shotgun Ammunition, Continued

---

### Officer awareness

The following table identifies factors that officers should consider when firing a shotgun at any potential threat.

Consideration	Explanation
<b>Distance from the Threat</b>	<ul style="list-style-type: none"><li>• All the pellets of a single round can be grouped within a human sized threat from a shotgun that is fired less than 20 yards away</li><li>• The <i>maximum effective range is approximately 40 yards</i>, although pellets can be lethal up to 200 yards or more</li></ul>
<b>Proximity of Noninvolved Persons and Surrounding Area</b>	<ul style="list-style-type: none"><li>• When firing from a distance that is greater than 20 yards, officers must consider the proximity of uninvolved persons and the size of shot spread that will be produced</li></ul>

---

### Rifled slugs

A **rifled slug** is a shotgun shell with a single round nose projectile. They are approximately one ounce in weight and are usually made of lead.

Rifled slugs are often used when increased precision, penetration, or range are required for the conditions presented.

---

# Wound Ballistics

[35.03.E07]

---

**Introduction** Peace officers need to understand how the ammunition they use affects their threats in order to be prepared and act accordingly in a tactical situation.

---

**Wound ballistics** Ballistics is the general study of projectiles in flight. Wound ballistics is the study of how a fired projectile affects tissue.

---

**Incapacitation** Incapacitation is the total removal of a person’s ability or power to act.

The “one shot stop” is a myth of television and movies. The ability of a single bullet to incapacitate a human being is statistically extremely low.

---

**Types of incapacitation** There are three ways in which a person who has been struck by one or more projectiles can be incapacitated. The following table identifies each.

Type of Incapacitation	Description
Central Nervous System (Neurological)	<ul style="list-style-type: none"><li>Any projectile that strikes the brain or spinal cord is capable of causing immediate incapacitation</li></ul>

---

*Continued on next page*

## Wound Ballistics, Continued

---

**Types of  
incapacitation**  
(continued)

<b>Type of Incapacitation</b>	<b>Description</b>
<b>Critical Blood Loss (Hematological)</b>	<ul style="list-style-type: none"><li>• Blood loss from damaged organs and vessels can lead to a drop in blood pressure causing the person to lose consciousness</li><li>• Highly dependent on bullet size and design</li><li>• Damage caused by tearing flesh or shearing muscle will result in blood loss</li><li>• Unless the heart, vena cava, or aorta are damaged, blood loss may be slow and will not incapacitate a person for some time</li></ul> <p>NOTE: Even a person shot through the heart can live and function for enough time to injure or kill an officer.</p>
<b>Psychologically</b>	<ul style="list-style-type: none"><li>• During a confrontation, some people are not aware they have been shot</li><li>• Others may overreact to minor wounds and collapse</li><li>• There is no true way to realistically assess a person's reactions to being shot and officers cannot count on psychological impact to cause incapacitation</li></ul>

---

# Chapter Synopsis

---

**Learning need** Peace officers must know, the capabilities and limitations of the ammunition they use in their firearms to operate them safely and effectively.

---

**Safe handling of ammunition**  
[35.03.EO1] Safety is as critically important when handling ammunition as it is when handling any firearm.

---

**Primary components of a handgun cartridge**  
[35.03.EO2] A cartridge is a self-contained unit which includes a projectile and propellant capable of firing the projectile through the barrel of a firearm. A bullet is the projectile this is expelled from the cartridge. A single cartridge is also called a round.

---

**Firing chain of events**  
[35.03.EO3] The primer is detonated causing the powder to ignite expanding gasses to force the bullet from the barrel of the firearm.

---

**Primary components of a shotgun shell**  
[35.03.EO4] A single round used in a shotgun is referred to as a shell. A shotgun shell can contain single or multiple projectiles. The projectiles contained in the shell are often referred to as the load.

---

**Shot patterns**  
[35.03.EO5, 35.03.EO6] A shot pattern is the diameter of a circle in which the shot will fit.  
The shot pattern will increase in size as the shot travels toward the threat. Test results indicate that the shot spread for No. 00 buckshot is approximately one inch for each yard of distance.

---

*Continued on next page*

## Chapter Synopsis, Continued

---

**Incapacitation**  
[35.03.E07]

There are three ways in which a person who has been struck by one or more projectiles can be incapacitated.

---

**Permanent  
cavity size**  
[35.03.E08]

The size of the permanent cavity created by a projectile.

---

# Workbook Learning Activities

---

## **Introduction**

To help you review and apply the material covered in this chapter, a selection of learning activities has been included. No answers are provided. However, by referring to the appropriate text, you should be able to prepare a response.

---

## **Activity questions**

1. Explain what happens to each component of a cartridge beginning when a firing pin/striker strikes its base.

---

*Continued on next page*

## Workbook Learning Activities, Continued

---

**Activity  
Questions**  
(continued)

2. A fleeing suspect is approximately 30 yards ahead of the pursuing officer. The suspect turns and fires a handgun, missing the officer and bystanders. A mother, about a yard to the right of the suspect, tries to shield her child as the officer in pursuit raises a shotgun. No one is behind the suspect. The officer is armed with a shotgun containing No. 00 buckshot. What factors should the officer consider before returning fire? Explain your reason for your answer. What is your agency's existing policy regarding a situation such as this?

---

*Continued on next page*





## Workbook Corrections

---

Suggested corrections to this workbook can be made by going to the POST website at: [www.post.ca.gov](http://www.post.ca.gov)

---

*Continued on next page*

## **Workbook Corrections,** Continued

---

**Student notes**

# Chapter 4

## Firearms Cleaning and Maintenance

### Overview

---

**Learning need** Peace officers must know how to properly inspect, clean, and care for their firearms to ensure that they function safely and effectively.

---

**Learning objectives** The chart below identifies the student learning objectives for this chapter.

<b>After completing study of this chapter, the student will be able to:</b>	<b>E.O. Code</b>
<ul style="list-style-type: none"><li>• Describe the components that may prevent problems and that should be examined during a routine safety inspection</li></ul>	35.04.EO1
<ul style="list-style-type: none"><li>• Describe the materials, equipment, and environment needed to properly clean firearms</li></ul>	35.04.EO2
<ul style="list-style-type: none"><li>• Apply routine procedures for cleaning firearms</li></ul>	35.04.EO3

---

*Continued on next page*

## Overview, Continued

---

**In this chapter** This chapter focuses on care and cleaning of firearms. Refer to the following chart for specific topics.

<b>Topic</b>	<b>See Page</b>
Safety Inspections	4-3
Cleaning Preparation Materials, Equipment, and Environment	4-8
Cleaning and Maintenance of Firearms	4-13
Chapter Synopsis	4-27
Workbook Learning Activities	4-28

---

# Safety Inspections

[35.04.EO1]

---

## **Introduction**

Poor firearm care can lead to serious problems and malfunctions of the firearm. It is the responsibility of all peace officers to ensure their firearms are always operational. A firearm that fails to function could cost officers their lives or the lives of others.

---

## **Symptoms of firearm failure**

Proper care includes paying attention to any symptom, no matter how large or small, that the firearm is not functioning properly.

Indications of firearm failure may include, but not be limited to:

- difficulty firing
  - moving parts that jam or bind
  - cartridges that do not feed properly
  - bulges or splits in the barrel
  - failure to fire when the trigger is pulled
- 

*Continued on next page*

## Safety Inspections, Continued

---

### Safety inspections

Peace officers should periodically perform a safety inspection on the operation of their firearms looking for potential problems. **Before any inspection is conducted, the firearm must be rendered safe.**

Problems that are identified during an inspection should be addressed as soon as possible. Only a few problems should be corrected by the officer. Complex problems should be corrected by a valid factory authorized **armorer**.

The following table identifies what should be inspected as well as whether a problem should be corrected by the officer or by an armorer.

When inspecting the:	Look for signs of:	Repaired by an:	
		Officer	Armorer
<b>Barrel</b>	bulges or splits		X
	obstructions	X	X
	rust	X	X
	heavy rust or pits		X
	a barrel that is loose from the frame		X
<b>Frame</b>	cracks		X
	wear		X
	heavy rust or pits		X
	light rust	X	
	powder build-up	X	
	loose mainspring tension screws		X

---

*Continued on next page*

## Safety Inspections, Continued

Safety inspections  
(continued)

When inspecting the:	Look for signs of:	Repaired by an:	
		Officer	Armorer
<b>Sights</b>	loose parts		X
	broken parts		X
	bent parts		X
<b>Cylinder</b>	poor or no free rotation when open	X	X
	jiggling or rotation by finger pressure when closed	X	X
	improper alignment with barrel		X
<b>Cylinder Release</b>	loose release	X	X
	loose screw	X	
<b>Firing Pin</b>	broken or chipped pin		X
	obstruction	X	X
<b>Grip</b>	broken grip	X	X
	loose grip	X	

*Continued on next page*

## Safety Inspections, Continued

Safety inspections  
(continued)

When inspecting the:	Look for signs of:	Repaired by an:	
		Officer	Armorer
Magazine	weakened spring		X
	dirt build-up	X	
	cracked body		X
	loose or bent floor plate		X
	bent lips		X
	follower not working properly	X	X

*Continued on next page*



## Safety Inspections, Continued

---

**Student notes** During class, instructors will demonstrate the procedures for conducting a safety inspection for the specific model of firearm that has been issued to each student.

# Cleaning Preparation Materials, Equipment, and Environment

[35.04.EO2]

---

**Introduction** Knowing when to clean a firearm, how to prepare for cleaning it, and the correct materials, equipment, and environment to use are essential to the proper care of a firearm.

---

**When to clean** All firearms should be cleaned:

- after firing or handling
- periodically as part of a preventive maintenance program
- when symptoms of firearm failure appear
- before and after storing for long periods of time
- when the firearm has been exposed to water, snow, rain, mist, etc.
- when the firearm comes into contact with dirt or debris

---

**Extent of required cleaning** Disassembly and extensive cleaning procedures may not always be required each time a firearm is cleaned. Depending on the firearm's handling and exposure to harmful elements, it may need:

- a simple wipe off after it has been briefly handled
  - a thorough cleaning with field strip if exposed to elements or heavy use
- 

**Environment and preparation** Firearms should only be cleaned in an area that is safe, well ventilated, and free of adverse conditions (e.g., dust, dirt, moisture, etc.), distractions, or bystanders. Before any actual cleaning procedures begin, officers should:

- put themselves in a positive and safety-minded state of mind
  - assemble all necessary equipment and materials
- 

*Continued on next page*

# Cleaning Preparation Materials, Equipment, and Environment, Continued

## Environment and preparation (continued)

- unload the firearm and magazine visually and physically inspect them
- place the ammunition in a safe and secure location away from the cleaning area

NOTE: Ammunition should be kept clean but *never* lubricated.

## Cleaning materials

Using appropriate materials, such as **solvents** and **lubricants**, is critical to the proper cleaning of the firearm. The following table identifies the materials that should be used when cleaning and maintaining a firearm.

Item	Description/Function
<b>Solvent</b>	<ul style="list-style-type: none"> <li>• Used to clean parts of the firearm</li> <li>• Loosens or dissolves lead deposits</li> <li>• Dissolves powder residue and lacquer-like chemical deposits from powder</li> <li>• Loosens, dissolves, and helps remove dirt, grime, and grit</li> <li>• Offers some rust protection</li> </ul> <p>NOTE: Only those solvents that are manufactured specifically for use with firearms should be used. Acids or strong industrial solvents may damage the firearm and should never be used (e.g., carburetor or brake cleaning solvents).</p> <p>NOTE: Repeated use of some solvents without thoroughly removing them may result in a sticky residue that hinders proper operation of the firearm.</p>

*Continued on next page*

# Cleaning Preparation Materials, Equipment, and Environment, Continued

Cleaning materials  
(continued)

Item	Description/Function
<b>Lubricant</b>	<ul style="list-style-type: none"> <li>• Protects metal parts and helps them work smoothly</li> <li>• Reduces friction and wear</li> <li>• Covers metal surfaces with a protective coating</li> <li>• Prevents moisture and other corrosive agents from contacting metals</li> <li>• Helps prevent rust caused by perspiration salts from handling</li> </ul>
<b>Cleaning Patches</b>	<ul style="list-style-type: none"> <li>• Absorbs excess solvents, lubricants, and rust inhibitors</li> <li>• Wipes metal surfaces clean</li> <li>• Removes salts and other deposits from handling</li> <li>• Should be clean, soft, and made from a lint free cotton or similar material</li> <li>• Can also be patches from major cleaning materials manufacturers or silicone-treated cloth</li> </ul>
<b>Personal Protection Materials</b>	<ul style="list-style-type: none"> <li>• Eye protection</li> <li>• Rubber gloves</li> </ul>
<b>Other Materials</b>	Pipe cleaners and cotton swabs for cleaning small areas when cleaning rags will not fit

*Continued on next page*

# Cleaning Preparation Materials, Equipment, and Environment, Continued

## Cleaning equipment

The following table identifies the equipment that should be assembled before any cleaning procedures begin.

Item	Description/Function
<b>Screwdriver(s)</b>	<ul style="list-style-type: none"><li>• Specifically designed to be used with firearms</li><li>• Should fit screw slots exactly to prevent damage to the screw or firearm surface</li></ul>
<b>Bore brush</b>	<ul style="list-style-type: none"><li>• Made to fit the specific size of the firearm</li><li>• Bristles are made of a material hard enough to remove stubborn deposits, but soft enough to protect the rifling of the bore</li></ul>
<b>Cylinder Brush</b>	<ul style="list-style-type: none"><li>• Used only when cleaning the cylinder of a revolver (never in the bore of the firearm)</li><li>• Slightly larger in diameter and longer than a bore brush</li></ul>
<b>Cleaning Brush</b>	<ul style="list-style-type: none"><li>• Can be a specially made cleaning brush or a common toothbrush</li><li>• Used to remove deposits, such as powder residue, from critical areas</li></ul>
<b>Cleaning Rod</b>	<ul style="list-style-type: none"><li>• Made of a metal that is softer than the metal of the barrel</li><li>• Should be stiff enough not to bend</li><li>• Should be longer than the barrel to ensure that it will clear the bore</li><li>• Equipped with a swivel handle and end that will accept a variety of threaded tips</li></ul>

*Continued on next page*

## Cleaning Preparation Materials, Equipment, and Environment, Continued

---

Cleaning equipment  
(continued)

Item	Description/Function
<b>Patch Holder or Tip</b>	<ul style="list-style-type: none"><li>• Holds cleaning patches securely when moved in either direction through the bore</li><li>• Slotted ends make it easier to attach cleaning patches</li></ul>
<b>Small Container</b>	<ul style="list-style-type: none"><li>• A small box or container should be used to store screws and other small parts during the cleaning process</li></ul>

---

# Cleaning and Maintenance of Firearms

[35.04.EO3]

---

## **Introduction to cleaning a semiautomatic pistol**

Cleaning and maintenance requirements differ from one make and model of a semiautomatic pistol to another. It is the responsibility of officers to be familiar with the cleaning and maintenance procedures for their specific firearm.

---

## **Render the firearm safe**

Before any disassembly or cleaning begins officers must:

- remove the magazine
  - lock the slide open
  - remove any unspent rounds from the chamber
  - inspect the chamber to verify that the firearm is empty
- 

## **Field strip disassembly**

Thorough cleaning of a semiautomatic requires field stripping the pistol and magazine. **Field strip** means the partial disassembly, complete wipe down and visual inspection of all the parts of the firearm and magazine. Disassembly beyond field stripping should only be done by a factory approved armorer or gunsmith.

---

*Continued on next page*

## Cleaning and Maintenance of Firearms, Continued

---

**Field  
strip  
disassembly  
(continued)**

<b>Field stripping includes...</b>	
disassembly of a <i>semiautomatic pistol</i> into the following components: <ul style="list-style-type: none"><li>• barrel assembly</li><li>• slide assembly</li><li>• slide stop</li><li>• recoil spring and guide assembly</li><li>• frame assembly</li></ul>	disassembly of a <i>magazine</i> into the following components: <ul style="list-style-type: none"><li>• floor plate</li><li>• tab</li><li>• spring</li><li>• follower</li><li>• magazine body</li><li>• base plate</li></ul>

NOTE: Officers should refer to the firearm manufacturer's guidelines for the instructions on the proper disassembly of that specific semiautomatic pistol.

---

*Continued on next page*



## Cleaning and Maintenance of Firearms, Continued

---

### **Routine cleaning**

There is no standard for the order in which components should be cleaned. No matter what order though, cleaning should be done in a thorough manner.

Cleaning and lubricating should be done according to the manufacturer's instructions and specifications for that specific firearm.

The following table identifies the steps that are common for cleaning most semiautomatic pistols.

<b>Component</b>	<b>Description</b>
<b>Barrel Assembly</b>	<ul style="list-style-type: none"><li>• Check for:<ul style="list-style-type: none"><li>- obstructions</li><li>- pitting of the lands and grooves</li><li>- signs of cracks, bulges, or other damage</li></ul></li><li>• Fold a cleaning patch and pull the corner through the slot of the cleaning patch holder</li><li>• Moisten the patch with cleaning solvent</li><li>• Patch should be moistened thoroughly but not soaked to the point of dripping</li><li>• Put the patch into the barrel from the chamber end and move it back and forth the entire length of the barrel 5-10 times to spread the solvent through the barrel</li><li>• Put a few drops of solvent on a bore brush</li><li>• Carefully push the brush <i>all the way through the barrel</i> from the chamber side and pull it back throughout the barrel</li><li>• Do not reverse the direction of the bore brush while it is in the barrel, as it may jam or scratch the barrel</li></ul>

---

*Continued on next page*

## Cleaning and Maintenance of Firearms, Continued

**Routine cleaning**  
(continued)

Component	Description
<b>Barrel Assembly</b> (continued)	<ul style="list-style-type: none"> <li>• Run a dry cleaning patch through the barrel to remove any solvent</li> <li>• Run a lightly lubricated patch through the barrel</li> <li>• Wipe the barrel exterior to remove any carbon or powder residue</li> <li>• Visually inspect to make sure all dirt and deposits have been removed</li> </ul>
<b>Recoil Spring and Guide Assembly</b>	<ul style="list-style-type: none"> <li>• Check for damage and that the guide rod and spring assemblies are not bent</li> <li>• Separate the recoil spring from the guide</li> <li>• Use a cloth to remove any carbon or powder residue</li> <li>• Visually inspect to make sure all dirt and deposits have been removed</li> </ul>
<b>Frame Assembly</b>	<ul style="list-style-type: none"> <li>• Check:             <ul style="list-style-type: none"> <li>- for bending, cracking or chips</li> <li>- guide rails for sharpness, cracks or wear</li> <li>- free movement of slide stop</li> <li>- hammer for cracking or other damage</li> </ul> </li> <li>• Put a few drops of solvent on a brush</li> <li>• Use the brush to gently clean the interior and exterior of the frame, including the slide rails, ejector, hammer, trigger action assembly, and magazine well</li> <li>• Use caution not to “scrub” any part of the frame</li> <li>• Use a cloth to wipe the interior and exterior areas of the frame to remove any remaining solvent, debris, carbon, or powder residue</li> </ul>

*Continued on next page*

## Cleaning and Maintenance of Firearms, Continued

---

**Routine  
cleaning**  
(continued)

Component	Description
<b>Frame Assembly</b> (continued)	<ul style="list-style-type: none"><li>• Apply a drop of lubricant to moving parts including the slide rails</li><li>• Visually inspect to make sure all dirt and deposits have been removed</li></ul>

NOTE: Do not dry fire firearm with slide removed as this may cause damage to the firearm.

---

*Continued on next page*

## Cleaning and Maintenance of Firearms, Continued

---

### Reassemble

Once all components of the semiautomatic pistol have been cleaned and the appropriate parts have been lubricated, the firearm should be reassembled per the manufacturer's guidelines.

---

### Cleaning magazines

The cleaning of the semiautomatic pistol is not complete unless the magazine has also been disassembled per the manufacturer's guidelines, cleaned, and reassembled.

Guidelines for cleaning a magazine include the following:

- Use the brush to clean the
  - interior and exterior of the magazine body
  - the feed lips of the magazine (use caution not to bend the lips)
  - follower
  - follower notch
  - tab
  - floor plate
  - base plate
- Use a cloth to wipe off remaining solvent, debris, carbon, or powder residue
- Use a cloth to remove carbon or powder residue from the magazine spring
- Reassemble magazine spring and follower in the correct position.
- Install the base plate after the floor plate

NOTE: Lubricants should never be used on a magazine. Ammunition in the magazine may become contaminated.

---

*Continued on next page*

## Cleaning and Maintenance of Firearms, Continued

---

### **Function check**

After the semiautomatic pistol and magazine have been cleaned and reassembled, officers should conduct a function check to make sure the firearm is working properly.

Function checks should include, but not be limited to examination of:

- the magazine
  - slide release
  - single- and double-action operation
  - the slide lock release
  - sight condition
  - trigger operation
  - the decocker mechanism
  - all safety mechanisms
- 

### **Reloading**

Once the function of the semiautomatic pistol has been checked and if the officer is returning to duty, the magazine and semiautomatic pistol should be properly reloaded and returned safely to the officer's holster.

If the officer is not returning to duty, the firearm should be securely stored.

---

### **Proper storage**

After cleaning and lubricating a semiautomatic pistol, the pistol should be properly secured and stored when not in use.

Appropriate storage containers include:

- a gun safe or vault
  - soft or hard framed security cases with padlocks, combination locks, or key pads
- 

*Continued on next page*

## Cleaning and Maintenance of Firearms, Continued

---

### **Proper storage** (continued)

If no secure container is available, a locking device should be used or the firearm should be disassembled to render it inoperable before storage.

NOTE: Firearms should not be wrapped in canvas, leather, or rags that can collect moisture and cause rust.

---

### **Periodic preventive maintenance**

Damp air and sweaty hands are great promoters of rust. Firearms should be inspected and periodically cleaned and lubricated, if necessary. Periodic cleaning does not necessarily involve field stripping the firearm into separate components. Instead, officers should:

- wipe the pistol with a clean cloth, then wipe it again with a silicone cloth
  - clean the bore with cleaning solvent, then remove any excess solvent with a dry patch
  - dust out all crevices with a small brush
- 

### **Routine service**

Warranties may require that a firearm be returned to the manufacturer or be taken to a factory authorized armorer for routine inspection and maintenance. Officers should refer to their specific firearm manual and agency policy to determine how often this routine service should take place.

---

*Continued on next page*

## Cleaning and Maintenance of Firearms, Continued

---

### Examples

- (1) After qualifying at a firing range, an officer went to the cleaning area and cleaned his pistol. When he was through, he inserted a loaded magazine into the pistol but forgot to chamber a live round. When back on duty, the officer also failed to conduct a routine chamber check of the firearm. Several weeks later he was involved in a deadly force situation requiring him to draw and fire his pistol. Since he was unaware of the condition of his firearm, his first trigger pull was on an empty chamber.
- (2) A new officer finished shooting her firearm at the range and returned to the cleaning area with a loaded firearm. She did not visually or physically conduct a chamber check before beginning to field strip the firearm. During disassembly, she pulled the trigger and fired the firearm. A hole was shot through the cleaning table.
- (3) A veteran police officer had just completed an intensive and exhausting five day safety and field tactics course. Although he had cleared his firearm prior to leaving the range, he reloaded it before returning home. Once he reached his home, he began cleaning the firearm. He removed the magazine but failed to remove the round in the chamber and did not keep his finger off the trigger while removing the slide. He pulled the trigger, causing it to discharge, shooting himself in the hand.

---

*Continued on next page*

## Cleaning and Maintenance of Firearms, Continued

---

### **Introduction to cleaning a revolver**

Revolvers should only be partially disassembled by peace officers for routine cleaning. Complete disassembly should only be done by a gunsmith or armorer.

---

### **Render the firearm safe**

Before any disassembly or cleaning begins, officers must:

- remove all rounds from the chambers of the cylinder
  - visually inspect each cylinder chamber to verify that it is empty
  - leave the cylinder open
- 

### **Precleaning inspection**

Before cleaning the revolver, visually inspect the firearm for:

- lead in the forward end of the cylinder
  - excessive lead on the face of the cylinder
  - excessive powder accumulation around or under the extractor head
  - debris in the firing pin recess (the opening that the firing pin travels through to strike the primer)
- 

### **Disassembly**

Disassembly involves the removal of the cylinder and yoke from the revolver's frame. Officers should take extra care not to misplace the cylinder screw during this process.

**NOTE:** Officers should refer to the firearm manufacturer's guidelines for instructions regarding proper disassembly.

---

*Continued on next page*



## Cleaning and Maintenance of Firearms, Continued

---

### Routine cleaning procedures

Cleaning and lubricating should be done according to the manufacturer's instructions and specifications for that specific firearm. The following table identifies the steps that are common for cleaning most revolvers.

Component	Description
<b>Barrel</b>	<ul style="list-style-type: none"><li>• Fold a cleaning patch and pull the corner through the slot of a cleaning patch holder</li><li>• Moisten the patch with cleaning solvent</li><li>• Patches should be moistened thoroughly but not soaked to the point of dripping</li><li>• Slide the patch into the barrel from the muzzle end</li><li>• Move patch back and forth the entire length of the barrel 5-10 times to spread the cleaning solvent through the bore</li><li>• Put a few drops of solvent on a bore brush and carefully run the brush all the way through the barrel into the cylinder opening</li><li>• Pull the bore brush back through the barrel</li><li>• Repeat 5-10 times using the bore brush</li><li>• Do not reverse the direction of the bore brush while it is in the barrel as it could jam or scratch the barrel</li><li>• Be careful not to jam the end of the bore brush into the firing pin opening in the frame</li></ul> <p>NOTE: Officers should <i>not</i> use a cylinder brush when cleaning the barrel.</p>

*Continued on next page*

## Cleaning and Maintenance of Firearms, Continued

**Routine  
cleaning  
procedures  
(continued)**

Component	Description
<b>Cylinder</b>	<ul style="list-style-type: none"> <li>• Use a cylinder brush (not a bore brush) to clean each chamber using the same procedures as cleaning the barrel</li> <li>• Rotate the cylinder in only one direction to be sure not to miss a chamber</li> <li>• Brush some solvent on the front and back faces of the cylinder with a toothbrush</li> <li>• Let the solvent stand for several minutes or more to loosen any deposits that are there</li> <li>• Using a toothbrush, brush some solvent on the area where the bullet enters the barrel</li> </ul>
<b>Other Areas</b>	<ul style="list-style-type: none"> <li>• Use a soft brush to remove powder residue, dirt, and dust from:               <ul style="list-style-type: none"> <li>- under the extractor head/star</li> <li>- behind the trigger</li> <li>- around the sights</li> </ul> </li> </ul>
<b>Remove Solvents</b>	<ul style="list-style-type: none"> <li>• Run fresh cleaning patches through the barrel until they come out clean and dry</li> <li>• Remove solvent from each chamber of the cylinder in the same way</li> <li>• Using clean, dry cleaning patches or a lint-free cloth, wipe off any excess solvent from all metal surfaces</li> </ul>
<b>Lubricate</b>	<ul style="list-style-type: none"> <li>• Refer to the manufacturer's guidelines regarding which moving parts should be lubricated</li> </ul>

*Continued on next page*

## Cleaning and Maintenance of Firearms, Continued

---

### Reassembly

Once the cleaning operation is complete, the revolver can be reassembled per the manufacturer's guidelines.

---

### Function check

After the revolver has been cleaned, officers should check the revolver function by dry firing several times to make sure the firearm is working properly.

Function checks should include, but not be limited to examination of:

- the barrel (with the cylinder open)
- cylinder movement (opening and closing as well as rotation while in place)
- cylinder release (on each chamber)
- firing pin movement through the face of the frame
- single- and double-action operation
- ejector rod operation

NOTE: Dry firing should always be done in a safe manner and area.

---

*Continued on next page*

## **Cleaning and Maintenance of Firearms, Continued**

---

**Student notes**      During class, instructors will demonstrate the procedures for disassembly, cleaning, and reassembly for the specific model of firearm that has been issued to each student.

# Chapter Synopsis

---

**Learning need** Peace officers must know how to properly inspect, clean, and care for their firearms to ensure that they function safely and effectively.

---

**Routine safety inspections**  
[35.04.EO1] Peace officers should periodically perform a safety inspection on the operation of their firearms looking for potential problems.

---

**Cleaning materials and equipment**  
[35.04.EO2] Appropriate cleaning materials and equipment should be assembled before any cleaning procedures begin.

---

**Cleaning firearms, both semiautomatic and revolvers**  
[35.04.EO3] All cleaning and lubricating of semiautomatic firearms should be done according to the manufacturer's instructions and specifications for that particular firearm.  
  
Cleaning and maintenance requirements differ from one make and model of a semiautomatic pistol to another. It is the responsibility of officers to be familiar with the cleaning and maintenance procedures for their specific firearm.

---



## Workbook Learning Activities, Continued

---

**Activity  
questions**  
(continued)

3. After using a cleaning patch to spread solvent through the barrel of his semiautomatic pistol, an officer carefully pushed a cylinder brush all the way through the barrel. The officer then pushed the brush gently back and forth in the barrel five to ten times. He ran a lubricated patch through the barrel and wiped off the barrel exterior. What errors did the officer make in cleaning the firearm? What effects could these errors have on the safe operation of the firearm?
  
4. While an officer is shooting on the firing line, the officer's semiautomatic pistol fails to fire. What should the officer do? List the possible reason for the malfunction.

---

*Continued on next page*

## Workbook Learning Activities, Continued

---

**Activity  
questions**  
(continued)

5. For each of the following circumstances, indicate the level of cleaning you believe the firearm needs and the reason for your decisions (e.g., simple wipe off, routine cleaning without disassembly, thorough cleaning with field strip, etc.).

When a cartridge fails to eject completely:

After firing:

When the firearm has been dropped in the snow:

When the firearm has been in storage for over a year:

After a foot pursuit through a dusty field:

---

*Continued on next page*



## Workbook Learning Activities, Continued

---

**Activity questions**  
(continued)

6. What is the officer attempting to accomplish in each of the following steps to clear the malfunction in a semiautomatic pistol?

<b>Step</b>	<b>Action</b>	<b>Explanation</b>
<b>1</b>	Firmly tap the bottom of the magazine with the heel of the support hand to make sure the magazine is in place and properly seated.	
<b>2</b>	Retract the slide to the rear and then release it to chamber a round. Make sure the pistol is in battery.	
<b>3</b>	Check condition of safety.	
<b>4</b>	Assess the threat.	

---

*Continued on next page*

## Workbook Learning Activities, Continued

---

**Activity  
questions**  
(continued)

7. Why should ammunition be kept in a location away from the area where a firearm will be cleaned? What would be the consequences if it is not?

# Chapter 5

## Basic Shooting

### Overview

---

**Learning need** Peace officers must comprehend and practice the fundamental skills of firing firearms to be effective in reactive and precision situations during live fire exercises.

---

**Learning objectives** The chart below identifies the student learning objectives for this chapter.

<b>After completing study of this chapter, the student will be able to:</b>	<b>E.O. Code</b>
<ul style="list-style-type: none"><li>• Apply the proper steps for drawing and holstering</li></ul>	35.05.EO1
<ul style="list-style-type: none"><li>• Demonstrate the following elements to accurately shoot a firearm:<ul style="list-style-type: none"><li>- Grip</li><li>- Stance</li><li>- Breath control</li><li>- Sight alignment/sight picture</li><li>- Trigger control</li><li>- Follow-through</li></ul></li></ul>	35.05.EO2 35.05.EO3 35.05.EO4 35.05.EO5 35.05.EO6 35.05.EO7
<ul style="list-style-type: none"><li>• Describe the types of malfunctions and demonstrate clearing methods for:<ul style="list-style-type: none"><li>- Semiautomatic pistols</li><li>- Revolvers</li><li>- Shotguns</li></ul></li></ul>	35.05.EO12 35.05.EO13 35.05.EO14

---

*Continued on next page*

## Overview, Continued

### Learning objectives (continued)

---

<b>After completing study of this chapter, the student will be able to:</b>	<b>E.O. Code</b>
<ul style="list-style-type: none"><li>• Describe limitations officers may encounter when shooting under low light/nighttime conditions</li></ul>	35.05.EO8
<ul style="list-style-type: none"><li>• Describe conditions an officer may face when in a combat situation</li></ul>	35.05.EO9
<ul style="list-style-type: none"><li>• Describe possible physiological and psychological responses an officer may experience under the stress of a combat situation</li></ul>	35.05.EO10
<ul style="list-style-type: none"><li>• Explain steps officers can take to prepare themselves for the extreme stress of combat</li></ul>	35.05.EO11

### In this chapter

This chapter focuses on the skills required to accurately shoot a handgun or shotgun. Refer to the following chart for specific topics.

---

<b>Topic</b>	<b>See Page</b>
Drawing and Holstering	5-3
Firearm Shooting Principles	5-6
Firearms Malfunctions	5-15
Shooting Under Low Light/Nighttime Conditions	5-22
Combat Shooting Skills	5-29
Combat Related Stress	5-37
Chapter Synopsis	5-47
Workbook Learning Activities	5-49

---

# Drawing and Holstering

[35.05.EO1]

---

## **Introduction**

The first step in using a firearm is removal from the officer's holster. In order to perform this function safely, officers should become thoroughly familiar with the operation of the holster they are using.

---

## **Holster functions**

Although holster designs can vary according to the needs for safety and keeping the firearm in place, all holsters must meet certain requirements.

An officer's holster should:

- securely hold the officer's firearm in the same position at all times
- allow the officer to draw the firearm quickly and safely
- withstand the stress of someone pulling on it violently
- have reinforced safety construction features to hold it securely and allow the officer to maintain control of the firearm

**NOTE:** It is each officer's responsibility to become familiar with the manufacturer's documentation for the care and use of the holster the officer is using.

---

## **Holster limitations**

At the same time, the officer's holster may have limitations the officer must be conscious of.

The officer should be aware that:

- with some styles of holsters, a downward grabbing motion by a suspect's hand from the front could cause the holster to unsnap
- holsters must be maintained in good condition and at all times be mechanically sound

**NOTE:** Peace officers are responsible for initiating the replacement of worn holsters.

---

*Continued on next page*

## Drawing and Holstering, Continued

---

### Drawing

**Drawing** is the removal of a firearm from the holster. Drawing a firearm should be done in a smooth, continuous motion with no wasted body movement.

---

### Drawing a firearm

When drawing a firearm, remember the third fundamental rule of firearm safety: **always keep your finger off the trigger until ready to fire the firearm.**

The ability to draw a firearm requires concentration and practice until all motions become fluid and natural. The primary steps of drawing a firearm are noted in the following table:

Step	Description
1	Acquire a grip with the primary hand on the firearm while at the same time releasing all safety restraining snaps or straps
2	In one smooth motion, lift the firearm out of the holster until the muzzle clears the holster. Keep the support hand away and clear of the muzzle
3	Extend the firearm downrange toward the intended target or threat or to a low ready position

---

*Continued on next page*

## Drawing and Holstering, Continued

---

### Holstering

**Holstering** is the placing of a firearm into the officer's holster so that it is secure and available for use.

NOTE: Holstering of firearms results in more peace officers wounding themselves than any other activity.

Holstering should be done in a methodical, smooth, continuous motion. When holstering, officers should keep their eyes on the threat, not on their holster.

The primary steps of holstering a firearm are noted in the following table.

Step	Description
1	Remove the trigger finger away from the trigger. Keep the trigger finger outside the trigger guard and away from the trigger
2	Decock the hammer of the firearm, if necessary
3	Keep support hand from crossing the muzzle of the firearm
4	Point the firearm downward toward the holster
5	Place the thumb of the primary hand over the rear of the slide
6	Firmly seat the firearm into the holster and release the grip
7	Refasten the holster safety snaps and straps

---

# Firearm Shooting Principles

[35.05.EO2, 35.05.EO3, 35.05.EO4, 35.05.EO5, 35.05.EO6, 35.05.EO7]

---

## Introduction

Proficiency with a firearm can only be developed through practice. Like any other psychomotor skill, shooting requires proper, adequate ongoing training and practice to maintain or increase an officer's level of shooting accuracy. Mastery of the principles of shooting is essential before an officer progresses to **combat** situations where speed and accuracy can mean the survival of the officer and others.

---

## Principles of accurate shooting

There are a number of principles that make up the foundation for the effective deployment of a firearm. Officers must develop proficiency in each in order to improve their overall accuracy. Each must be learned and practiced in a static position (i.e., on a practice range) before they can be applied automatically by the officer under tactical conditions.

The principles of firearm shooting accuracy are:

- grip
  - stance
  - breath control
  - sight alignment/sight picture
  - trigger control
  - follow-through
- 

## Proficiency

There are a number of specific techniques for employing each of the principles of shooting accuracy. The lessons within this chapter focus only on the *basic principles* associated with each principle. Instructors will be discussing and demonstrating *specific techniques* during class and on the firing range for developing an adequate level of skill in each.

---

*Continued on next page*



## Firearm Shooting Principles, Continued

---

### Grip

**Grip** is the manner in which the firearm is held. The grip must be firm without being too tight. Holding the firearm with too tight a grip can cause the hand to tremble.

Although it is possible and sometimes necessary to fire using a one hand grip, the two-handed grip, which gives better control, is recommended most.

NOTE: Grip is also the term used to refer to the handle of the firearm.

---

### Characteristics of a proper grip

Characteristics of a proper firearm and shotgun grip are noted in the following table.

Firearm Grip	Shotgun Grip
<ul style="list-style-type: none"><li>• Web of the palm of the primary hand is placed as high as possible on the back strap of the firearm</li><li>• Index finger remains off the trigger. (This position may vary some depending on the specific firearm.)</li><li>• Front sight, rear sight, and radial bone of the forearm are in alignment when the firearm is raised to a shooting position</li></ul>	<ul style="list-style-type: none"><li>• Primary hand is properly placed on the pistol grip of the shotgun</li><li>• Support hand is forward on the fore end of the shotgun</li><li>• Grip of both hands is firm and equal</li></ul>

*Continued on next page*

## Firearm Shooting Principles, Continued

---

### Shouldering the shotgun

Shouldering (sometimes referred to as mounting) the shotgun is the process of bringing the firearm up to a shooting position. Characteristics of a properly shouldered shotgun are noted below.

- The primary side elbow may be raised
  - The butt of the stock is in the pocket which is formed in the chest and shoulder areas, just inside the deltoid muscle
  - The shooter's primary side cheek should contact the comb of the stock
  - The support elbow is drawn inward so that it is positioned directly below the shotgun
- 

### Stance

**Stance** is the physical positioning of the shooter's body when preparing to shoot a firearm or shotgun.

The following table describes the most common stances used by peace officers.

Stance	Characteristics
Isosceles	<ul style="list-style-type: none"><li>• The shooter is facing the target</li><li>• Shoulders are squared and both arms are forward and straight</li><li>• Shoulders and arms form an isosceles triangle</li></ul>

---

*Continued on next page*

## Firearm Shooting Principles, Continued

### Stance (continued)

Stance	Characteristics
<b>Weaver</b>	<ul style="list-style-type: none"> <li>The shooter stands in a position of interview at a 45 degree angle to the suspect with the support hand forward, wedged toward the target</li> <li>The shooting arm elbow is slightly bent</li> </ul>
<b>Modified Weaver</b>	<ul style="list-style-type: none"> <li>The shooter stands in a position of interview at a 45 degree angle to the suspect with the support hand forward, wedged toward the target</li> <li>Primary arm is locked at the elbow</li> </ul>

### Characteristics of a proper stance

Characteristics of proper firearm and shotgun stances are noted in the following table.

Firearm Stance	Shotgun Stance
<ul style="list-style-type: none"> <li>Feet are shoulder width apart</li> <li>Weight is evenly distributed</li> <li>Upper body is upright or bent slightly forward</li> <li>Head and neck are kept erect</li> <li>Shooter is able to move in any direction</li> </ul>	<ul style="list-style-type: none"> <li>Feet are shoulder width apart</li> <li>Upper body is bent forward at waist</li> <li>Support side knee is forward and bent</li> <li>Primary side hip is to the rear</li> <li>Weight is slightly forward</li> <li>Head and neck are kept erect</li> <li>Shooter is able to move in any direction</li> </ul>

*Continued on next page*

## Firearm Shooting Principles, Continued

---

### Shooting positions

Stance is also closely related to shooting position. There are a variety of acceptable shooting positions that have been developed to enhance the officer's accuracy under varied conditions.

The following table identifies a number of the advantages and disadvantages officers should be aware of for each shooting position they may employ under combat conditions.

<b>Shooting Position</b>	<b>Advantages</b>	<b>Disadvantages</b>
<b>Standing</b>	<ul style="list-style-type: none"><li>• Better visibility</li><li>• Greater mobility</li><li>• Allows the officer to pivot and engage multiple targets</li></ul>	<ul style="list-style-type: none"><li>• Greater officer exposure</li></ul>
<b>Kneeling</b>	<ul style="list-style-type: none"><li>• May be used for close range encounters</li><li>• Easy to assume</li><li>• Provides less exposure of the officer than standing</li><li>• Allows the officer to pivot and engage multiple targets</li><li>• Officer can utilize low cover</li></ul>	<ul style="list-style-type: none"><li>• Less mobility</li><li>• Limited visibility</li></ul>
<b>Prone</b>	<ul style="list-style-type: none"><li>• Provides minimal exposure of the officer</li><li>• Officer can utilize low cover</li></ul>	<ul style="list-style-type: none"><li>• Limited mobility</li><li>• Limited visibility</li></ul>

---

*Continued on next page*

## Firearm Shooting Principles, Continued

---

### Controlled breathing

When an officer breathes, that officer's body moves. Proper breath control can assist the officer in firing an accurate shot or series of shots. This is especially true when using the sights of the firearm.

When shooting a firearm, officers should breathe in a smooth normal manner.

---

### Sight alignment and sight picture

**Sight alignment** is the relationship between the shooter's eye, and the front and rear sights of the firearm.

A **sight picture** is when the shooter's focus is on the top center of the *front sight* and the rear sight and aiming point (target) is out of focus.

The following identifies the proper method for establishing sight alignment.

Action	Description
<b>Align the Sights</b>	<ul style="list-style-type: none"><li>• When the decision to shoot has been made, center the front sight in the notch of the rear sight</li><li>• The top of the front site should be level with the top of the rear sight</li><li>• Equal amounts of light should be visible on either side of the front sight as viewed through the rear sight</li></ul>
<b>Align Target</b>	<ul style="list-style-type: none"><li>• Place the top center of the front sight exactly on the desired point of impact (aiming point) on the target</li></ul>
<b>Establish a Sight Picture</b>	<ul style="list-style-type: none"><li>• Focus sharply on the top center of the <i>front sight</i></li><li>• The rear sight and aiming point should be blurry</li></ul>

NOTE: A graphic illustration of proper sight alignment is provided in the *Supplementary Material* of this workbook.

---

*Continued on next page*

## Firearm Shooting Principles, Continued

---

### Trigger control

**Trigger control** is the process of using smooth continuous pressure on the trigger without disturbing the sight picture.

The majority of all errors and/or misses are caused by poor trigger control. No matter how perfectly the shooter grips the firearm, assumes a stance, or aligns the sights, if the trigger is jerked in anticipation of the discharge, the shot will not be accurate.

---

### Independent trigger finger

The trigger finger must operate *independently*. The shooter's thumb or other fingers of the firing and supporting hand should never "help" the trigger finger.

Trigger control requires concentration and discipline. No one can hold a firearm absolutely still, but an officer can improve with practice.

---

### Achieving trigger control

Trigger control is accomplished by:

- placing the center of the index finger tip pad on the trigger
- applying a smooth continuous pressure on the trigger
- pulling straight to the rear with no stops or jerks
- maintaining the sight alignment of the firearm until the firearm fires

NOTE: The exact moment of the hammer fall and discharge of the firearm should always be a surprise to the shooter. Anticipating the blast or recoil will cause the shooter to flinch and pull the muzzle downward just as the bullet is being fired.

---

*Continued on next page*

## Firearm Shooting Principles, Continued

---

### Follow-through

**Follow-through** is the continuation of all the principles of firearm shooting after the shot has been fired. The following table identifies the proper sequence of events for achieving proper follow-through.

Step	Action
1	Concentrate on the front sight constantly throughout the firing sequence
2	Maintain the trigger in the rearward position until the firearm is brought out of recoil
3	Maintain the sight picture
4	Prepare to shoot again if necessary

---

*Continued on next page*

## Firearm Shooting Principles, Continued

---

**Student notes** During class, instructors will demonstrate each of the skills necessary for shooting accuracy. Demonstrations will include proper firearm and shotgun grips, stances, breath control, sight alignment, trigger control, and follow-through.



# Firearm Malfunctions

[35.05.EO12, 35.05.EO13, 35.05.EO14]

---

## **Introduction**

A malfunction is an unexpected interruption in the firing sequence. Some malfunctions may be cleared (fixed) by the officers while others involving severe jams or broken parts require a factory authorized armorer to correct.

---

## **Basic guidelines**

All malfunctions are potentially dangerous and should be attended to as soon as reasonably possible. The ability to immediately recognize and clear firearm malfunctions may be essential to officer safety.

If a firearm malfunctions, officers should:

- remove their trigger finger from and keep other fingers away from the trigger of the firearm
  - keep the firearm pointed in a safe direction
  - use the appropriate method for clearing the malfunction
- 

*Continued on next page*

## Firearm Malfunctions, Continued

### Malfunctions involving semiautomatic pistols

There are numerous possible causes of malfunctions involving semiautomatic pistols. The following table identifies several types of malfunctions and some of the most common causes for each.

Malfunction	Description	Possible Cause
<p><b>Failure to Fire</b></p> <p>Note: May also be referred to as a misfire</p>	<p>Trigger is pulled, hammer falls, but no projectile is discharged from the pistol</p>	<ul style="list-style-type: none"> <li>• Check safety</li> <li>• Improperly seated magazine (round cannot be fed into the chamber)</li> <li>• Defective cartridge</li> <li>• No round in the chamber</li> <li>• Empty magazine</li> <li>• Defective firearm</li> </ul>
<p><b>Failure to Eject</b></p> <p>Note: May also be referred to as “stove pipe” jam</p>	<p>Spent cartridge fails to completely eject and protrudes from the ejection port</p>	<ul style="list-style-type: none"> <li>• Improper lubrication</li> <li>• Improperly functioning extractor or ejector</li> <li>• Defective cartridge</li> <li>• Improper grip</li> <li>• Defective firearm</li> </ul>
<p><b>Failure to Extract</b></p> <p>Note: May also be referred to as a feedway stoppage or double feed jam</p>	<p>Two cartridges attempt to feed into the chamber at the same time</p>	<ul style="list-style-type: none"> <li>• Damaged extractor</li> <li>• Damaged magazine</li> <li>• Unextracted cartridge case</li> <li>• Dirty chamber</li> <li>• Defective firearm</li> </ul>

*Continued on next page*

## Firearm Malfunctions, Continued

### Malfunctions involving semiautomatic pistols (continued)

Malfunction	Description	Possible Cause
<b>Failure to Feed</b>  Note: May also be referred to as failure to chamber	Cartridge does not feed into the chamber	<ul style="list-style-type: none"> <li>• Magazine not fully seated into the magazine well</li> <li>• Use of an oversized cartridge case</li> <li>• Dirty chamber</li> <li>• Defective firearm</li> </ul>

### Clearing semiautomatic pistol malfunctions

If a malfunction is encountered, officers should take the following actions to clear the malfunction.

	Step	Description
<b>First Attempt</b>	<b>1</b>	Firmly tap the bottom of the magazine with the heel of the support hand to make sure the magazine is in place and properly seated
	<b>2</b>	Retract the slide to the rear and then release it to chamber a round. Make sure the pistol is in battery
	<b>3</b>	Check safety/decocker lever as applicable
	<b>4</b>	Assess the threat

*Continued on next page*

## Firearm Malfunctions, Continued

### Clearing semiautomatic pistol malfunctions (continued)

	Step	Description
<b>Second Attempt</b> (if the pistol continues to malfunction)	<b>1</b>	Lock slide to the rear
	<b>2</b>	Remove magazine
	<b>3</b>	Rack, as necessary, to clear the chamber
	<b>4</b>	Lock slide rearward
	<b>5</b>	Insert new magazine
	<b>6</b>	Release slide
	<b>7</b>	Assess the threat

### Malfunctions involving revolvers

The following table identifies several types of malfunctions involving revolvers along with some of the most common causes for each.

Malfunction	Description	Possible Cause
<b>Failure to Fire</b>	Trigger is pulled, hammer falls, but no projectile is discharged from the revolver	<ul style="list-style-type: none"> <li>• No round in chamber</li> <li>• Defective cartridge</li> <li>• Defective firearm</li> </ul>

*Continued on next page*

## Firearm Malfunctions, Continued

---

### Malfunctions involving revolvers (continued)

Malfunction	Description	Possible Cause
<b>Slow Cylinder</b>	Cylinder does not properly rotate	<ul style="list-style-type: none"><li>• Dirty firearm</li><li>• Improperly seated primer in the cartridge</li><li>• Broken spring</li><li>• Loose ejector rod</li><li>• Loose retaining screw</li><li>• Defective firearm</li></ul>
<b>Stopped Cylinder</b>	Cylinder fails to move at all	<ul style="list-style-type: none"><li>• Cylinder not completely closed</li><li>• Defective firearm</li></ul>

---

### Clearing revolver malfunctions

If a malfunction is encountered by an officer, that officer should:

- open the cylinder
  - remove any observed defective cartridge(s)
  - reload new cartridge(s) into the chamber
  - close the cylinder
  - assess the threat
  - pull trigger again
- 

*Continued on next page*

## Firearm Malfunctions, Continued

### Malfunctions involving shotguns

The following table identifies several types of malfunctions involving shotguns along with some of the most common causes for each.

Malfunction	Description	Possible Cause
<b>Failure to Fire</b> Note: May also be referred to as a misfire	Trigger is pulled, hammer falls, but no projectile is discharged from the shotgun	<ul style="list-style-type: none"> <li>• No round in the chamber</li> <li>• Defective cartridge</li> <li>• Broken firing pin</li> <li>• Bolt not locked into place</li> </ul>
<b>Failure to Eject</b> Note: May also be referred to as “stove pipe” jam	Empty shell has been extracted from the chamber and protrudes from the ejection port rather than being ejected clear from the shotgun	<ul style="list-style-type: none"> <li>• Failure to fully and briskly rack the action</li> <li>• Bent action bars</li> <li>• Broken/damaged extractor</li> </ul>
<b>Double Feed</b> Note: May also be referred to as a feedway stoppage	Action does not close after the shotgun has been fired and an attempt has been made to cycle the action	<ul style="list-style-type: none"> <li>• Empty shell remains in the chamber (new shell cannot enter)</li> <li>• Broken/damaged extractor</li> </ul>
<b>Failure to Fully Chamber</b>	Shell fails to chamber completely after the action has been cycled	<ul style="list-style-type: none"> <li>• Dirty chamber</li> <li>• Use of an oversized shell case</li> <li>• Action out of battery</li> </ul>
<b>Stacked Feed</b>	Action will not open	<ul style="list-style-type: none"> <li>• Shell in chamber while another is on the carrier plate</li> </ul>

*Continued on next page*

## Firearm Malfunctions, Continued

---

### Clearing shotgun malfunctions

If a shotgun malfunctions, officers should:

- check the condition of the safety
- rack the shotgun to chamber a shell
- assess the threat

If the shotgun continues to malfunction, officers should seek assistance.

---

### Failure to clear malfunctions

If an officer has attempted to clear the semiautomatic pistol, revolver, or shotgun malfunction and the firearm continues to malfunction, officers should take the following actions.

<b>IF officers are:</b>	<b>THEN the officers should:</b>
on the firing line at a range	<ul style="list-style-type: none"><li>• clear firearm according to academy policy</li></ul>
in a tactical situation	<ul style="list-style-type: none"><li>• transition to a different firearm or seek cover</li></ul>

**NOTE:** If unable to clear malfunction, raise hand and wait for assistance from an instructor or range master.

---

# Shooting Under Low Light/Nighttime Conditions

[35.05.EO8]

---

## Introduction

Peace officers must often function in situations under low light or nighttime conditions. Accuracy when shooting a firearm under such conditions can be greatly reduced unless officers make the necessary accommodations.

---

## Limitations

The following table identifies a number of problems and limitations that officers should be aware of when operating a firearm under low light/nighttime conditions.

<b>Limitation</b>	<b>Explanation</b>
<b>Night Vision</b>	<ul style="list-style-type: none"><li>• Adaptation to light and dark is only partly controlled by the pupil</li><li>• Although the eye becomes accustomed to bright light quickly, it may take from 10-30 minutes to allow the officer to see fully in the dark again</li></ul>
<b>Limited Depth Perception</b>	<ul style="list-style-type: none"><li>• As the lighting level drops, depth perception become impaired</li><li>• Once the level drops to a point where colors cannot be distinguished, an officer's depth perception can be greatly limited</li><li>• Shades of grey appear to be less clear than colors</li></ul>
<b>Limited Target Identification</b>	<ul style="list-style-type: none"><li>• Identification of subjects and hand-held objects becomes difficult</li><li>• As the amount of light continues to diminish or if the distance increases, accurate identification may be impossible without artificial light (e.g., flashlight)</li></ul>

---

*Continued on next page*



## Shooting Under Low Light/Nighttime Conditions, Continued

---

### Limitations (continued)

Limitation	Explanation
<b>Flash Disorientation</b>	<ul style="list-style-type: none"><li>• When the eye is subjected to repeated intense light (e.g., strobe light, numerous muzzle flashes), the perception of movement becomes difficult</li><li>• Disorientation becomes even more severe if the source of light is viewed directly</li></ul>
<b>Officer Limitations</b>	<ul style="list-style-type: none"><li>• Focus and adaptation times can increase as the officer ages (particularly after 40)</li><li>• Vision may also be impaired by:<ul style="list-style-type: none"><li>- some prescription and nonprescription medications</li><li>- poor physical condition</li><li>- certain illness (e.g., diabetes) may degrade vision</li><li>- use of tobacco and/or caffeine</li></ul></li></ul>

### Scanning

In low light conditions, slow lateral visual scanning will allow officers to peripherally detect what is in front of them. Scanning should start at a point near the officer and move out to a distance of approximately 45 feet.

---

*Continued on next page*

## Shooting Under Low Light/Nighttime Conditions, Continued

---

### Other senses

An officer's senses, other than vision, may be heightened in low light situations. The following table identifies what officers should be aware of.

<b>Sense</b>	<b>Explanation</b>
<b>Hearing</b>	<ul style="list-style-type: none"><li>• Listen for both hard and soft sounds that may signal movement or danger</li></ul>
<b>Smell</b>	<ul style="list-style-type: none"><li>• Be aware of smells in the area such as chemicals, alcohol, or gunpowder that may indicate the presence of people, objects or activities</li></ul>
<b>Touch</b>	<ul style="list-style-type: none"><li>• Make note of temperature changes or vibrations</li></ul>
<b>Intuition</b>	<ul style="list-style-type: none"><li>• The “sixth sense” is often developed from experience and should never be ignored</li></ul>

---

*Continued on next page*

## Shooting Under Low Light/Nighttime Conditions, Continued

---

### Sight alignment in low light

Occasionally officers may find themselves in a situation where there is insufficient light. There is enough light to clearly identify the threat but insufficient light for proper sight alignment.

The amount of light that is available can determine the tactics an officer may choose to use.

<b>IF there is sufficient:</b>	<b>THEN officers may use that light to:</b>
<ul style="list-style-type: none"><li>• ambient light</li></ul>	<ul style="list-style-type: none"><li>• align their sights and establish a sight picture</li></ul>
<ul style="list-style-type: none"><li>• back light</li></ul>	<ul style="list-style-type: none"><li>• observe the outline of their firearms' sights as seen against the illuminated area</li></ul>

In either case, if already engaged in a combat situation and ambient and back light are sufficient, officers may take advantage of the light provided by the muzzle flash to make corrections.

**NOTE:** Officers must be aware that this technique requires skills gained with practice.

---

*Continued on next page*

## Shooting Under Low Light/Nighttime Conditions, Continued

---

### Shooting with a flashlight

Many of the problems associated with low light/nighttime shooting can be reduced by the proper and efficient use of a flashlight. There are several techniques that can be used when shooting with the aid of a flashlight. The following table identifies two of the most common.

Technique One	Technique Two
<ul style="list-style-type: none"><li>• Flashlight is brought to a carry position with the support hand</li><li>• At the same time, the firearm is being thrust forward to a shooting position by the primary hand</li><li>• Flashlight may be turned on in any carry position (i.e., body of the light resting on the support side shoulder; body of the light resting against the support side hip)</li><li>• Lenses of the light should be forward and parallel to the ground</li></ul>	<ul style="list-style-type: none"><li>• Firearm is carried in the primary hand using a one-handed grip</li><li>• Flashlight is held in the support hand using an overhand grip</li><li>• Support hand is placed under the primary hand bringing the backs of both wrists together</li><li>• Elbow of the support hand should point straight down</li><li>• Primary hand should be pushed to the right while at the same time the left hand is pushed to the left to provide stability</li></ul>

---

*Continued on next page*

## Shooting Under Low Light/Nighttime Conditions, Continued

---

**Shooting  
with a  
flashlight**  
(continued)

Technique One	Technique Two
<ul style="list-style-type: none"><li>• Advantages:<ul style="list-style-type: none"><li>- Efficient and simple movements</li><li>- Fastest way of engaging a threat <i>from a search position</i></li></ul></li><li>• Disadvantages:<ul style="list-style-type: none"><li>- Requires the officer to be proficient with firing a firearm using a one-handed grip</li><li>- Requires coordination between both hands to keep the light on the threat and maintain the sight picture</li></ul></li></ul>	<ul style="list-style-type: none"><li>• Advantages:<ul style="list-style-type: none"><li>- Flashlight and firearm act as one unit allowing for more control and stability</li><li>- More effective when contact with a threat is anticipated</li></ul></li><li>• Disadvantage:<ul style="list-style-type: none"><li>- Requires coordination on the part of the officer to keep the light on the threat and maintain the sight picture</li></ul></li></ul>

---

*Continued on next page*

## Shooting Under Low Light/Nighttime Conditions, Continued

---

**Student notes** During class, instructors will demonstrate the skills necessary for shooting under low light/nighttime conditions. Demonstrations will include scanning techniques, sight alignment in low light, and use of a flashlight while shooting.

# Combat Shooting Skills

[35.05.EO9]

---

## **Introduction**

Shooting a firearm under combat conditions requires an officer to integrate all of the basic principles of shooting with the tactical and defensive techniques required for survival. It also requires both physical and emotional skills that must be established and practiced right along with shooting skills.

---

## **Decision making**

Decision making involves the elimination of inappropriate options and the selection of an option that can be executed. Officers must make conscious decisions to react based on their threat assessment.

Combat often requires officers to make split second decisions. Mental preparation is just as critical for an officer's survival as physical preparation. With mental preparation, split second decisions are more likely to be made without hesitation.

---

## **Levels of force**

Levels of force employed by officers in combat situations should be based on the level of the threat. Force options may include but are not limited to the use of:

- controlling force including physical compliance techniques
  - chemical agents (e.g., OC spray)
  - impact weapons (e.g., baton)
  - firearms and deadly force
- 

## **Deadly force**

Deadly force means any force that is likely to cause death or serious bodily injury. The use of firearms against an opponent is the deployment of deadly force.

---

*Continued on next page*

## Combat Shooting Skills, Continued

---

### Legal standard for use of deadly force

In 1985, the U.S. Supreme Court set a four part legal standard for the use of deadly force. This standard was based on a person's Fourth Amendment protection from unreasonable acts by peace officers (*Tennessee v. Garner*). The Court's analysis required balancing a person's fundamental interest in safety against the government's interest in effective law enforcement.

---

### Prerequisites for deadly force

The Court established the following prerequisites to an officer using deadly force in the line of duty.

Prerequisite	Court Ruling
<b>Life-Threatening Circumstance</b>	"Where the officer has probable cause to believe that the suspect poses a <i>threat of serious physical harm</i> , either to the officer or others..."
<b>Life-Threatening Felony</b>	"...if the suspect threatens the officer with a firearm or there is probable cause to believe that he has committed a <i>crime involving the infliction of serious bodily harm</i> ..."
<b>Give Warning Where Feasible</b>	"...the court imposes a constitutional requirement that <i>some warning</i> be given prior to the use of deadly force <i>where feasible</i> ..." "Halt, police! Stop or I'll shoot!"
<b>If Necessary to Prevent Escape</b>	"...in order for deadly force to be constitutionally permissible, there must be <i>probable cause to believe that the use of deadly force is reasonably necessary</i> ..."

NOTE: This federal constitutional standard is only the baseline for use of deadly force. Conditions under which deadly force may be employed are strictly controlled by agency policy. **Officers must be aware of and conform to these policies** regardless of what federal or state law might allow.

---

*Continued on next page*



## Combat Shooting Skills, Continued

---

### **Combat conditions**

There are a number of conditions officers may face in combat that they would not encounter under normal working conditions.

Combat related conditions may include:

- rapid threat assessment
  - shoot/no shoot decisions
  - multiple targets
  - moving targets
  - varying target distances
  - multiple shooting positions
  - movement
  - use of cover or concealment
- 

### **Balancing speed and accuracy**

In a combat situation when shooting becomes necessary, officers must discharge their firearms quickly--but not so fast that their shooting accuracy is compromised. Officers must balance speed with accuracy.

Officers should fire at a speed which allows them to utilize principles of accurate shooting. If officers shoot faster than they can maintain control, they will miss their target.

---

### **Threat assessment**

Officers must develop the ability to intelligently and objectively identify threats to their safety and the safety of others. Factors that officers must consider when assessing a potential threat include the:

- nature of the threat that must be overcome
  - presence of a firearm and the type of firearm
  - seriousness of the offense
- 

*Continued on next page*

## Combat Shooting Skills, Continued

---

### Threat assessment (continued)

- person's age, history, and capabilities
  - officer's capability to overcome the resistance
  - availability of assistance from other officers
  - location and surroundings including the:
    - level of danger to bystanders
    - time of day
- 

### Divided attention

When engaged in a combat situation, an officer's attention can be divided by:

- multiple threats
- moving threats
- changes in the terrain or environment
- varying distances between the officer and number of threats
- varying firearms used against the officer
- sudden changes in the actions or movements of the threat

Officers may encounter more than one armed threat. Officers in this situation who are justified in the use of deadly force should *engage the suspect that is the greatest threat first*.

---

### Tactical movement

Tactical movement is often necessary while in a combat situation.

When moving while under such conditions, officers should:

- move with the trigger finger positioned straight on the frame (i.e., indexing)
  - move the muzzle of the firearm along with their eyes in a search pattern
  - flex their legs during movement to create a stable shooting platform, keeping the upper torso erect without crouching
  - be prepared to assume a kneeling or prone position if necessary to engage a threat
- 

*Continued on next page*

## Combat Shooting Skills, Continued

---

### Shooting on the move

Any time an officer is required to move during a tactical situation, there is the potential that the officer may have to shoot while moving.

When shooting while moving, officers should:

- avoid positioning their bodies in such a way that they are unable to take a shot
- not attempt to time the actual firing of their shots with any particular part of their movement (e.g., shooting only when weight is on the support foot)
- fire in as normal a manner as possible

NOTE: Because the officer's focus is downrange on the threat, the hazard of falling or tripping and the firearm unintentionally discharging can be significant. To prevent this, officers should keep their trigger finger off the trigger until they are ready to shoot.

---

*Continued on next page*

## Combat Shooting Skills, Continued

---

### Cover and concealment

Peace officers should always be aware of surrounding objects or areas that may be utilized for **cover** or **concealment**. The following table identifies both forms of protection.

	<b>Cover</b>	<b>Concealment</b>
<b>Definition</b>	<ul style="list-style-type: none"><li>• Anything that may stop or deflect an opponent's bullets</li></ul>	<ul style="list-style-type: none"><li>• Anything that prevents an opponent from observing the officer</li></ul>
<b>Guidelines for Use</b>	<ul style="list-style-type: none"><li>• Should be used when involved in an armed encounter if possible</li><li>• The type of cover selected will depend on the type of fire received (firearm, shotgun, rifle)</li></ul>	<ul style="list-style-type: none"><li>• Will not stop bullets</li></ul>
<b>Examples</b>	<ul style="list-style-type: none"><li>• Cement block or brick walls</li><li>• Buildings</li><li>• Portion of the vehicle with the engine block</li><li>• Trees</li></ul>	<ul style="list-style-type: none"><li>• Shrubs or bushes</li><li>• Dark doorways</li><li>• Portions of the vehicle away from the engine block</li></ul>

---

*Continued on next page*

## Combat Shooting Skills, Continued

---

### **Barricade shooting**

The use of a barricade as cover may be critical in a deadly confrontation. Effective use of a barricade can greatly increase an officer's safety and allow for more accurate shooting.

The following table identifies two common techniques for barricade shooting.

<b>Primary Side Position</b>	<b>Support Side Position</b>
<ul style="list-style-type: none"><li>• Assume a bladed stance with the primary foot to the rear and the support foot forward</li></ul>	<ul style="list-style-type: none"><li>• Assume a bladed stance with the support foot to the rear and the primary foot forward</li></ul>
<ul style="list-style-type: none"><li>• Draw firearm and assume a two-hand stance</li></ul>	<ul style="list-style-type: none"><li>• Draw firearm and transfer it to the support hand</li></ul>
<ul style="list-style-type: none"><li>• Rest the back of the support hand on the side of the barricade while maintaining a normal grip. Discharge the firearm in a normal manner</li></ul>	<ul style="list-style-type: none"><li>• Discharge the firearm in a normal manner</li></ul>
<ul style="list-style-type: none"><li>• Allow only a small portion of the head and firearm to protrude beyond the barricade</li></ul>	<ul style="list-style-type: none"><li>• Allow only minimal amount of the firearm and the support side of the head to protrude beyond the barricade</li></ul>

---

*Continued on next page*

## Combat Shooting Skills, Continued

---

**Student notes** During class, instructors will demonstrate the skills necessary for combat shooting. Demonstrations will include tactical movement, shooting on the move, and the use of cover, concealment, and barricades.

# Combat Related Stress

[35.05.EO10, 35.05.EO11]

---

## Introduction

**Stress** is a nonspecific response of the body to any demand made on it. Combat is a physically and emotionally draining experience that may cause extreme stress. Such levels of stress can have both physical and psychological effects on peace officers both during and after combat related situations.

---

## Motor skills

In order to understand the human body's response to the extreme stress of combat, it is important to recognize the physical motor skills which officers must rely on. The following table identifies the different types of motor skills.

Motor Skill	Description	Examples
<b>Gross</b>	<ul style="list-style-type: none"><li>• Skills which generally involve the actions of the large or major muscle groups</li><li>• Usually requires strength and endurance</li></ul>	<ul style="list-style-type: none"><li>• Running</li><li>• Jumping</li><li>• Lifting</li><li>• Pushing/pulling</li></ul>
<b>Fine</b>	<ul style="list-style-type: none"><li>• Skills which are performed by small muscle masses or groups such as hands and fingers</li><li>• Frequently involves hand-eye coordination</li></ul>	<ul style="list-style-type: none"><li>• Sight alignment</li><li>• Shooting a firearm accurately</li><li>• Working with equipment such as handcuffs</li></ul>

---

*Continued on next page*

## Combat Related Stress, Continued

---

**Motor skills**  
(continued)

<b>Motor Skill</b>	<b>Description</b>	<b>Examples</b>
<b>Complex</b>	<ul style="list-style-type: none"><li>• Skills which involve hand-eye coordination, timing or tracking, and have multiple components</li><li>• Skills which combine a series of individual muscle group actions to form a single event</li></ul>	<ul style="list-style-type: none"><li>• Shooting while moving</li><li>• Complex physical control techniques</li></ul>

---

**“Fight or flight”**

An individual under the continual and extreme stress of combat will experience a release of adrenaline, epinephrine, and nor-epinephrine hormones into the bloodstream.

The substances are produced by the body normally as part of the “**fight** or flight” reflex and can cause:

- an increased heart rate (faster blood circulation)
  - a dramatic increase in the consumption of oxygen (rapid breathing to replace oxygen)
  - an increase in the heart’s contractibility (sense of the heart “pounding”)
  - possible reduction in perception of pain
  - elevated levels of strength
- 

*Continued on next page*



## Combat Related Stress, Continued

---

### Physiological effects on motor skills

The physiological responses can have a dramatic affect on an officer's motor skills under the extreme stress of combat. The following table identifies a number of these effects.

Motor Skill	Effects
<b>Gross</b>	<ul style="list-style-type: none"><li>• Blood supply to the major muscle groups is increased</li><li>• An individual's strength and endurance potential is increased</li><li>• Skills can be performed optimally under extreme levels of stress (e.g., ability to lift heavy objects)</li></ul>
<b>Fine</b>	<ul style="list-style-type: none"><li>• Blood supply to the extremities is decreased</li><li>• Accuracy and dexterity of fine skills are impaired under extreme levels of stress (e.g., loss of hand coordination)</li></ul>
<b>Complex</b>	<ul style="list-style-type: none"><li>• Blood supply to the extremities is decreased</li><li>• Accuracy and dexterity of fine skills are impaired under extreme levels of stress (e.g., difficulty coordinating movements such as shooting and moving at the same time)</li></ul>

### Heart rate and reaction time

An officer's heart rate can be directly related to the ability to function under the extreme stress of combat. When a threat is perceived, an officer's heart rate can increase from 70 to 200 beats per minute in approximately six seconds.

*Continued on next page*

## Combat Related Stress, Continued

---

### Heart rate and reaction time (continued)

The following table identifies the effects an officer's heart rate may have on that officer's ability to function.

Approximate Beats/Minute	Possible Physical Effect
70-90	<ul style="list-style-type: none"><li>• Optimum level for fine motor skills</li></ul>
115	<ul style="list-style-type: none"><li>• Maximum threshold for fine motor skills</li></ul>
145	<ul style="list-style-type: none"><li>• Optimum survival and combat performance</li></ul>
150-175	<ul style="list-style-type: none"><li>• Pupils dilate and flatten</li><li>• Loss of near vision</li><li>• Loss of depth perception</li></ul>
175	<ul style="list-style-type: none"><li>• Ability to process information is impaired</li><li>• Perception time increases by 440%. (What took one second to perceive under normal conditions will now take 4.4 seconds.)</li><li>• Hyper vigilance</li><li>• Irrational behavior</li></ul>

### Controlled breathing

Learning how to control one's breathing can be key to maintaining motor skills. Slow, controlled breathing, when done in times of extreme stress, helps the body "de-escalate" and lowers the heart rate to a more efficient rate.

Practicing breath control in quiet times (e.g., at home, on routine patrol, etc.) will help officers apply the same control in times of stress.

---

*Continued on next page*

## Combat Related Stress, Continued

---

### **Controlled breathing** (continued)

An appropriate breath control exercise to practice consists of repeatedly:

- taking a deep breath
  - holding it for four seconds
  - releasing it over a period of four seconds
  - waiting four seconds before taking the next deep breath
- 

### **Other physiological effects**

Along with motor skills, there are a number of additional physiological effects a peace officer may experience in response to the extreme stress of combat. The following table identifies a number of these possible effects.

<b>Effect</b>	<b>Additional Information</b>
<b>Auditory Changes</b>	<ul style="list-style-type: none"><li>• Inability to hear shots being fired or other loud noises</li><li>• Hearing sounds that would normally be impossible to hear</li></ul>
<b>Tunnel Vision</b>	<ul style="list-style-type: none"><li>• Distorted or impaired peripheral vision</li></ul>
<b>Color Distortion</b>	<ul style="list-style-type: none"><li>• Seeing colors that are different from what they actually are</li></ul>
<b>Time Distortion</b>	<ul style="list-style-type: none"><li>• A sense of time and motion slowing down</li></ul>
<b>Physical Detachment</b>	<ul style="list-style-type: none"><li>• A sense of watching oneself function</li></ul>

---

*Continued on next page*

## Combat Related Stress, Continued

---

### Other physiological effects (continued)

Effect	Additional Information
Other	<ul style="list-style-type: none"><li>• Dizziness</li><li>• Profuse perspiration</li><li>• Tremors</li><li>• Extreme thirst</li><li>• Urination/defecation</li><li>• Vomiting</li></ul>

---

### Psychological responses

Along with physiological responses, officers may experience psychological responses to the extreme stress of combat.

**Fear** is a normal emotional response to a perceived threat. Courage or bravery is *not* the lack of fear, but in fact, the *control of fear*. Fear does not become a problem until it interferes with the ability to perform effectively.

---

### Reasonable fear

Reasonable fear may result when an officer experiences increased stress in response to a potential threat during a combat situation.

Officers may experience reasonable fear as a result of:

- a sudden sound produced outside one's field of vision
- a sudden or erratic move by a suspect
- the sight of a firearm in a suspect's possession
- knowledge that one is in danger of bodily harm

The physical and mental preparation of their training allows officers to use fear appropriately and not allow it to become a barrier to reaching their objectives.

---

*Continued on next page*

## Combat Related Stress, Continued

---

### Anger

**Anger** is a feeling of displeasure from a perceived injury, mistreatment, or opposition to oneself or to another person. When anger is inappropriate or out of control (i.e., rage), it can become a liability to an officer's performance.

Officers have reported that anger, appropriately channeled, has enabled them to keep fighting, during a crisis situation.

---

### Post combat responses

A combat situation is not over when the last shot is fired. The extreme stress of combat can cause numerous physiological and psychological effects following the incident. Peace officers should be aware of such possible responses and recognize them as normal and seek additional support or aid if necessary to deal with them.

The following table identifies possible post combat responses that peace officers may experience.

	Possible Post Combat Responses
<b>Physiological</b>	<ul style="list-style-type: none"><li>• Chronic tension or irritability (i.e., inability to relax)</li><li>• Insomnia</li><li>• Constant fatigue</li><li>• Impaired concentration and memory</li><li>• Flashbacks (voluntary or involuntary)</li><li>• Loss of sexual interest or impotence</li><li>• Sexual promiscuousness</li><li>• Inability to tolerate noise</li><li>• Easily startled (i.e., "jumpy")</li></ul>

*Continued on next page*

---

## Combat Related Stress, Continued

**Post  
combat  
responses  
(continued)**

	<b>Possible Post Combat Responses</b>
<b>Psychological</b>	<ul style="list-style-type: none"> <li>• Guilt</li> <li>• Denial</li> <li>• Feelings of anxiety or sadness</li> <li>• Self-doubt regarding actions, responses, etc.</li> <li>• Clinical depression</li> <li>• Placement of blame on department or others</li> <li>• Fear of facing a similar incident again</li> </ul>
<b>Other</b>	<ul style="list-style-type: none"> <li>• Family life becomes difficult or violent</li> <li>• Social withdrawal (including from one's spouse or family members)</li> </ul>

**Managing  
stress**

Officers must prepare both physically and mentally to manage the extreme stress of combat long before any critical incident takes place.

The following table identifies a number of ways officers can prepare themselves to handle the extreme stress of combat as well as post combat related responses.

	<b>Rationale</b>
<b>Mental Preparation</b>	<ul style="list-style-type: none"> <li>• Visualizing possible threats and worst-case scenarios allows officers to identify possible responses (e.g., "what if..." exercises)</li> <li>• Discussing possible scenarios with other officers can also help one officer benefit from another's experiences (good and bad)</li> </ul>

*Continued on next page*

## Combat Related Stress, Continued

**Managing stress**  
(continued)

	<b>Rationale</b>
<b>Physical Conditioning</b>	<ul style="list-style-type: none"> <li>• Regular exercise is critical to ensure that an officer will be physically capable of performing adequately when placed in a combat situation</li> <li>• Use of tobacco or tobacco related products will compromise an officer's lung capacity and that officer's ability to breath as well as place the officer at risk of serious illness</li> </ul>
<b>Proper Nutrition</b>	<ul style="list-style-type: none"> <li>• Following good nutritional practices can greatly affect an officer's performance under stress</li> <li>• Caffeine can accelerate the heart rate and should be used in moderation</li> </ul>
<b>Equipment Maintenance</b>	<ul style="list-style-type: none"> <li>• Knowing that a firearm is well maintained and always ready for operation is critical for officer safety and the safety of others</li> </ul>
<b>Confidence Building</b>	<ul style="list-style-type: none"> <li>• Confidence is a mind set that is based upon past experiences and observations</li> <li>• Confidence can be enhanced by learning new skills while maintaining or increasing the level of proficiency in existing skills</li> <li>• Confidence in personal abilities may lower heart rate during confrontation allowing for optimum performance</li> </ul>

*Continued on next page*

## Combat Related Stress, Continued

---

**Managing stress**  
(continued)

	<b>Rationale</b>
<b>Initial and Ongoing Training</b>	<ul style="list-style-type: none"><li>• Skills that are learned in a static, non-stressful environment (closed motor skills) translate best to reactionary motor skills in a dynamic environment (open motor skills)</li><li>• All motor skills, gross and fine, require constant practice in order to maintain adequate levels of performance</li><li>• Additional or refresher training can correct problems that may have developed over time as well as improve current levels of ability and enhance self-confidence</li></ul>
<b>Support Groups</b>	<ul style="list-style-type: none"><li>• Many agencies have some form of support for an officer involved in a critical incident</li><li>• Support groups may be comprised of fellow officers who have experienced similar occurrences</li><li>• One-on-one counseling may also be available (e.g., peer counselors, professional counselor, chaplain, etc.)</li></ul>

---



# Chapter Synopsis

---

**Learning need** Peace officers must comprehend and practice the fundamental skills of firing firearms to be effective in reactive and precision situations during live fire exercises.

---

**Drawing and holstering a firearm [35.05.EO1]** The ability to draw a firearm requires concentration and practice until all motions become fluid and natural.

---

**Proper grip [35.05.EO2]** Grip is the manner in which the firearm is held. The grip must be firm without being too tight.

---

**Stance [35.05.EO3]** Stance is the physical positioning of the shooter's body when preparing to shoot a firearm.

---

**Breath control [35.05.EO4]** When an officer breathes, that officer's body moves. Proper breath control can assist the shooter in firing an accurate shot or series of shots. This is especially true when using the sights of the firearm.

When shooting a firearm, officers should breathe in a smooth normal manner.

---

**Sight alignment/ sight pictures [35.05.EO5]** Sight alignment is the relationship between the officer's eye, and the front and rear sights of the firearm. Sight picture is when the shooter's focus is on the top center of the front sight and the rear sight and aiming point (target) is out of focus.

---

**Trigger control [35.05.EO6]** Trigger control is the process of using smooth continuous pressure on the trigger without disturbing the sight picture.

---

*Continued on next page*

## Chapter Synopsis, Continued

---

**Follow-through**  
[35.05.E07]

Follow-through is the continuation of all the principles of firearm shooting after the shot has been fired.

---

**Firearm malfunctions**  
[35.05.E012,  
35.05.E013,  
35.03.E014]

A malfunction is an unexpected interruption in the firing sequence. Some malfunctions may be cleared (fixed) by the officers while others involving severe jams or broken parts require a factory authorized armorer to correct

---

**Low light/  
nighttime  
shooting**  
[35.05.E08]

Accuracy when shooting a firearm under low light or nighttime conditions can be greatly reduced unless officers make the necessary accommodations.

---

**Combat related conditions**  
[35.05.E09]

There are a number of conditions that officers may be faced with while in combat that they would not encounter under normal working conditions.

---

**Affects of the extreme stress of combat**  
[35.05.E010,  
35.05.E011]

Stress is a nonspecific response of the body to any demand made on it. Combat is a physically and emotionally draining experience that may cause extreme stress. Such levels of stress can have both physical and psychological effects on peace officers both during and after combat related situations.

---

## Workbook Learning Activities

---

### **Introduction**

To help you review and apply the material covered in this chapter, a selection of learning activities has been included. No answers are provided. However, by referring to the appropriate text, you should be able to prepare a response.

---

### **Activity questions**

1. In your own words, describe the circumstances under which an officer may use deadly force.
  
  
  
  
  
  
  
  
  
  
  
  
  
2. You respond to a call of a possible stalker outside a residence. The homeowner explains that she has a restraining order against her ex-husband who has threatened her life. Her dog has been barking constantly, and she has seen what she thinks was a dark figure in her backyard. As you and your partner go outside to investigate, you see an image move, then stop near a hedge. You hear what you believe is a shotgun being racked. Describe what actions you might take. Explain the reasons for your answers.

---

*Continued on next page*

## Workbook Learning Activities, Continued

---

**Activity questions**  
(continued)

3. Think about your most recent experience shooting a firearm on a firing range. Honestly assess your performance and consider how you can improve your accuracy. Use the chart below to comment on your mastery of each of the key elements affecting your ability to shoot a firearm accurately.

	<b>Personal Assessment</b>
<b>Grip</b>	
<b>Stance</b>	
<b>Controlled breathing</b>	
<b>Sight alignment/sight picture</b>	
<b>Trigger control</b>	
<b>Follow-through</b>	

---

*Continued on next page*

## Workbook Learning Activities, Continued

---

**Activity questions**  
(continued)

4. You are engaged in a foot pursuit with a homicide suspect who has already fired shots with a firearm at you and your partner. The suspect, who is about 20 feet ahead of you, drops a gym bag and stops to retrieve it. His pause gives you an opportunity to stop and raise your own firearm. Describe what you see through your sights as you take aim.
  
  
  
  
  
  
  
  
  
  
  
  
  
5. Continuing the scenario in the above item; the suspect sees you raise your firearm. He raises his in what appears to be an attempt to fire. Describe what is happening to your body physically and psychologically as you recognize that you are facing a deadly threat. How might each affect your ability to react?

---

*Continued on next page*

## Workbook Learning Activities, Continued

---

**Activity  
questions**  
(continued)

6. You and your partner respond to a call of shots fired at a highway rest stop. As you approach the building on foot, one suspect, who is approximately 15 feet away, fires at you from the building's entry way with a firearm. Another suspect, who is approximately 40 feet away, has a rifle raised to his eye level and is running toward a parked vehicle. There is commotion inside the building and you hear someone screaming. You are not aware if there are other suspects inside the building. You have your firearm, but you are too far away from your vehicle to reach a shotgun. What type of cover will you look for? What other actions will you take? Give the reasons for your answers.

# Chapter 6

## Chemical Agents

### Overview

---

**Learning need** Peace officers must know the terminology, capabilities, exposure symptoms, and decontamination procedures in order to safely and effectively handle and deploy chemical agents and gas masks.

---

**Learning objectives** The chart below identifies the student learning objectives for this chapter.

<b>After completing study of this chapter, the student will be able to:</b>	<b>E.O. Code</b>
<ul style="list-style-type: none"><li>• State the statutory requirements for the possession and use of chemical agents</li></ul>	35.06.EO1
<ul style="list-style-type: none"><li>• Describe four methods used to deploy chemical agents</li></ul>	35.06.EO3
<ul style="list-style-type: none"><li>• Describe environmental and physical conditions that can impact the effectiveness of a chemical agent</li></ul>	35.06.EO4
<ul style="list-style-type: none"><li>• State the guidelines for safely carrying, drawing, and deploying hand-held canisters of chemical agents</li></ul>	35.06.EO5
<ul style="list-style-type: none"><li>• Apply decontamination procedures that should be followed after a chemical agent has been used</li></ul>	35.06.EO6
<ul style="list-style-type: none"><li>• Discuss the physiological and psychological effects of each of the following chemical agents used by peace officers:<ul style="list-style-type: none"><li>- OC (oleoresin capsicum)</li><li>- CN (chloroacetophenone)</li><li>- CS (ortho-chlorobenzylidene-molonitrile)</li></ul></li></ul>	35.06.EO7 35.06.EO8 35.06.EO9

---

*Continued on next page*

## Overview, Continued

### Learning objectives (continued)

---

<b>After completing study of this chapter, the student will be able to:</b>	<b>E.O. Code</b>
<ul style="list-style-type: none"><li>• Demonstrate proper procedures peace officers should follow when using gas masks, to include:<ul style="list-style-type: none"><li>- inspection and proper fit</li><li>- cleaning and storage</li></ul></li></ul>	35.06.EO10 35.06.EO11

### In this chapter

This chapter focuses on types and characteristics of the chemical agents used by peace officers. Refer to the following chart for specific topics.

<b>Topic</b>	<b>See Page</b>
Legal Issues Regarding Use and Possession	6-3
Safe and Effective Use	6-8
OC (Oleoresin Capsicum)	6-19
CN (Chloroacetophenone) and CS (Ortho-chlorobenzylidene-malononitrile)	6-23
Gas Masks	6-28
Chapter Synopsis	6-34
Workbook Learning Activities	6-36

---



# Legal Issues Regarding Use and Possession

[35.06.E01]

---

## Introduction

Under statutory law, peace officers may use chemical agents once they have satisfactorily completed instruction in their use. (*Penal Code Sections 835a and 22820*)

There are a variety of situations where peace officers may use chemical agents. Examples of such situations include, but are not limited to:

- self defense
  - overcoming the resistance of a noncompliant individual
  - effecting an arrest
  - preventing escape
  - crowd or riot control
  - dangerous animals
- 

## Related terms

In order to understand the legal issues regarding the use and possession of chemical agents, peace officers need to become familiar with the following terms.

**Tear gas** means all liquid, gaseous, or solid substances intended to produce temporary discomfort or permanent injury through being vaporized or otherwise dispersed in the air. (*Penal Code Section 17240*)

A **chemical agent device** is any shell, cartridge, or bomb capable of being discharged or exploded which allows the release of a chemical agent. It also includes any revolver, pistol, fountain pen gun, or other device intended for the release of tear gas. (*Penal Code Section 17250*)

---

## Law enforcement use of chemical agents

In statutory law the term “tear gas” is used as a generic term for all chemical agents. Only specified persons may lawfully possess or use any chemical agent that is intended to produce temporary discomfort or permanent injury.

---

*Continued on next page*

## Legal Issues Regarding Use and Possession, Continued

### Unlawful possession

*Penal Code Section 22900* states that any person, firm, or corporation who within this state:

- knowingly sells or offers for sale, possesses, or transports
- any tear gas or tear gas weapon
- *except as permitted* under the provisions of this chapter, is guilty of a public offense

### Conditions for lawful possession

Statutory law allows the possession and use of chemical agents for certain professions other than peace officers under specific conditions. The following table identifies these professions and conditions.

Possession of tear gas by:	is considered lawful when:	<i>Penal Code Section</i>
<b>Military and Naval Personnel</b>	<ul style="list-style-type: none"> <li>• purchased, possessed, transported, or used in the discharge of their duties</li> </ul>	22830
<b>Federal Law Enforcement Officers</b>		
<b>County Custodial Officers</b>	<ul style="list-style-type: none"> <li>• used while on duty</li> <li>• the officer has satisfactorily completed a course of instruction in the use of the chemical agent</li> </ul>	22825
<b>Private Investigators</b>	<ul style="list-style-type: none"> <li>• used solely for defensive purposes</li> <li>• in the course of the activity for which their licenses were issued</li> <li>• the person has satisfactorily completed a course of instruction in the use of the chemical agent</li> </ul>	22835
<b>Private Patrol Operators</b>		

*Continued on next page*

## Legal Issues Regarding Use and Possession, Continued

---

### Possession by the general public

In September of 1993, members of the general public were first allowed to use tear gas as a form of self-defense.

*Penal Code Section 22810(a) - (e)(1)* makes it lawful for a member of the general public to purchase, possess, or use a tear gas weapon if that person:

- uses it **solely for self-defense** and
  - has not been convicted of a felony or crime involving assault
  - is not addicted to narcotics
  - is not attempting to sell or furnish the tear gas weapon to a minor
  - the weapon is an **aerosol spray containing no more than 2.5 ounces**
- 

### Possession by a minor

*Penal Code Section 22815(a)* states that it is lawful for a minor to purchase and possess a chemical weapon *only* if that minor:

- has attained the age of 16 years, **and**
- is accompanied by a parent or guardian
- has written consent of a parent or guardian

NOTE: The minor must also meet the requirements of *Penal Code Section 22810(a) - (e)(1)*.

---

*Continued on next page*

## Legal Issues Regarding Use and Possession, Continued

---

### Product labeling

All manufacturers of chemical agents for use by the general public must comply with specific labeling requirements. (*Penal Code Section 22810*)

The following table identifies a number of the regulations regarding the labeling of these products.

Area	Description
Warning	Products authorized for possession by citizens must clearly display the following statement:  <b>“WARNING: The use of this substance or device for any purpose other than self defense is a felony under the law. The contents are dangerous - use with care.”</b>
Expiration	Every canister or weapon manufactured after January 1, 1984, must have the product’s expiration date displayed on the label
Manufacturer	Each product must display: <ul style="list-style-type: none"><li>- the manufacturer’s name</li><li>- a serial number</li></ul>

---

*Continued on next page*

## Legal Issues Regarding Use and Possession, Continued

---

### **Altering product labels**

It is a felony to alter the label of a product containing a chemical agent. (*Penal Code Section 22910*)

Altering includes:

- changing, altering, removing, or obliterating
- the manufacturer's name
- the product's serial number
- any identification marks

Possession of any device with an altered label can be used as *presumptive evidence* that the possessor is the person who actually altered the product.

---

### **Federal law**

It is a violation of federal law to carry or place a chemical agent device onto an aircraft. Penalties for the violation include:

- civil penalties including fines up to \$1,000 levied by the Department of Transportation
  - criminal penalties for the willful placement of up to five years in a federal prison and/or a fine of \$25,000
- 

### **Passenger aircraft**

It is unlawful to carry any nonlethal chemical agents within the passenger compartment of commercial aircraft. In 1998 an exception was made for aerosol canisters of 4 ounces or less that are intended for self-defense use. Such devices are allowed only in *checked* luggage though that is stowed in the luggage compartment of the aircraft. (*49 CFR Part 171 et al. and 49 CFR 175.10(a)(4)ii*)

---

# Safe and Effective Use

[35.06.EO3, 35.06.EO4, 35.06.EO5, 35.06.EO6]

---

## Introduction

Selection of a method for deploying a chemical agent is dependent on the purpose of its intended use and environmental conditions.

---

## Deployment methods

There are four methods that can be used to deploy chemical agents. The following table describes each.

Method	Description
<b>Aerosol</b>	<ul style="list-style-type: none"><li>• Expelling force (i.e., canister) is used to project the chemical agent</li><li>• Agent is dispersed at the desired target</li><li>• <i>Most common method used by law enforcement</i></li></ul>
<b>Fogging</b>	<ul style="list-style-type: none"><li>• Hot gasses are used to vaporize the liquid chemical agent</li><li>• Released into the air as a fog cloud</li><li>• Deployment devices are commonly referred to as “pepper foggers”</li></ul>
<b>Pyrotechnics</b>	<ul style="list-style-type: none"><li>• Burning of a granulated chemical agent in a pyrotechnic mixture</li><li>• Released into the air as a smoke cloud</li><li>• Also referred to as continuous discharge</li><li>• Extreme fire hazard</li></ul>
<b>Blast Expulsion</b>	<ul style="list-style-type: none"><li>• Use of explosives or other force to eject a micro-pulverized chemical agent into the air</li><li>• Also referred to as instantaneous discharge or bursting</li></ul>

---

*Continued on next page*

## Safe and Effective Use, Continued

---

### Environmental and physical conditions

All methods used to deploy chemical agents can be affected by certain environmental and physical conditions. Officers should recognize these conditions and take the appropriate precautions before deploying a chemical agent. The following table identifies these conditions:

Condition	Additional Information
<b>Wind</b>	<ul style="list-style-type: none"><li>• Agents dispersed into the wind may drift back onto the officers and involve bystanders</li><li>• Both wind <i>direction</i> and <i>speed</i> should be considered</li><li>• Gusting winds and direction changes can be common in urban areas where buildings can channel winds and cause turbulence</li></ul>
<b>Rain</b>	<ul style="list-style-type: none"><li>• Light rain may assist in settling an agent on the intended target</li><li>• Heavy rain can dampen the clouding effect and dissipate agents too quickly</li></ul>
<b>Temperature</b>	<ul style="list-style-type: none"><li>• On a hot day, disbursement may drift upwards</li></ul>
<b>Distance</b>	<ul style="list-style-type: none"><li>• Most hand-held devices have a <i>maximum</i> effective range of approximately 15 feet. (Some products may be less.)</li><li>• Some aerosol canisters can be used within 3-12 feet of the target</li><li>• Officers must remain constantly alert and prepared to take other action when in close proximity to a violent or potentially violent suspect</li></ul>

---

*Continued on next page*

## Safe and Effective Use, Continued

---

### Environmental and physical conditions (continued)

Condition	Additional Information
<b>Proximity of Others</b>	<ul style="list-style-type: none"><li>• Bystanders in the area may be exposed if they are near the area where the agent is used</li><li>• Officers who are physically engaged in subduing the suspect can inadvertently be exposed to the agent as well</li></ul>

NOTE: If an agent is being deployed for the purposes of crowd control, many other factors must be taken into consideration.

---

### Basic nomenclature: hand-held aerosol canister

The chemical agents most commonly used by peace officers are packaged in hand-held aerosol canisters. The following table identifies the basic components of a hand-held aerosol canister.

Component	Description/Function
<b>Safety Lock Hood</b>	<ul style="list-style-type: none"><li>• Device that prevents unintended release of the chemical agent</li></ul>
<b>Actuator</b>	<ul style="list-style-type: none"><li>• Mechanism that is pressed by the thumb or finger to release the chemical agent</li></ul>
<b>Discharge Nozzle</b>	<ul style="list-style-type: none"><li>• Point where the chemical agent is released into the air</li></ul>
<b>Pressurized Gas</b>	<ul style="list-style-type: none"><li>• Expands as the canister is emptied</li></ul>

---

*Continued on next page*



## Safe and Effective Use, Continued

### Basic nomenclature: hand-held aerosol canister (continued)

Component	Description/Function
Dip Tube	<ul style="list-style-type: none"><li>• Transports chemical agent from the canister to the discharge nozzle</li></ul>
Chemical Agent	<ul style="list-style-type: none"><li>• Active ingredients of the chemical agent</li></ul>
Outer Casing	<ul style="list-style-type: none"><li>• Outer canister that holds the chemical agent and pressurized gas</li></ul>

NOTE: A graphic illustration of a hand-held aerosol canister is provided in the *Supplementary Material* of this workbook.

### Canister care and maintenance

All hand-held canisters should be maintained according to the manufacturer's specifications. Individual agency policies may dictate when canisters should be replaced (whether they have been used or not).

The following table identifies basic guidelines for the care and maintenance of hand-held canisters.

	Explanation
Storage	<ul style="list-style-type: none"><li>• All devices containing chemical agents should be stored in an area that is inaccessible to children and untrained individuals</li><li>• Canisters should be stored in an area with good ventilation and out of direct sun</li><li>• Temperatures should never exceed 120 degrees F</li></ul> <p>NOTE: Above 120 degrees, the aerosol may expand causing the canister to explode.</p>

*Continued on next page*

## Safe and Effective Use, Continued

---

### Canister care and maintenance (continued)

	<b>Explanation</b>
<b>Maintenance</b>	<ul style="list-style-type: none"><li>• Officers should shake the canister on a regular basis</li><li>• This ensures that the active ingredients remain properly mixed</li></ul>
<b>Inspection</b>	<ul style="list-style-type: none"><li>• All hand-held canisters should be inspected on a regular basis</li><li>• Inspections should include:<ul style="list-style-type: none"><li>- canister exterior (e.g., seams, seals)</li><li>- activation mechanism</li><li>- nozzle for obstructions or blockages</li><li>- any signs of leaks</li></ul></li><li>• Faulty, empty, and nearly empty canisters should be replaced as necessary</li><li>• Test shots of the device should be conducted in a well ventilated area and away from other persons</li><li>• Expiration dates should be noted and honored</li></ul>

### Carrying hand-held canisters

Hand-held canisters can be worn on the officer's duty belt or other form of holster. Canisters can also be concealed within clothing, bags, or other cases.

When carrying a hand-held canister, officers should keep the device in a location that:

- is accessible when needed
- minimizes the chance of unintentional discharge

---

*Continued on next page*

## Safe and Effective Use, Continued

---

### **Drawing hand-held canisters**

When a hand-held canister is drawn, either from a holster or other location, officers should first make sure it is right-side-up. Canisters which are not held upright will not discharge properly and can lead to loss of the propellant.

It may be tactically advantageous to conceal the canister from the suspect until it is actually used.

Officers must also be able to quickly and easily reholster and secure the device in order to take control of the suspect. Both drawing and reholstering are skills that will require practice.

---

### **Safety mechanism**

Many canisters containing chemical agents have a spring-activated cover that functions as a safety lock. This safety cover is easily moved out of the way as the officer engages the firing actuator. As the finger or thumb is removed from the actuator, a spring brings the safety hood back into place.

---

### **Deploying the chemical agent**

The target for all hand-held aerosol agents is the *face of the suspect*.

---

### **Response to exposure**

Each person may have a different response or reaction when exposed to a chemical agent. The same person may react differently on different occasions depending on the conditions.

---

*Continued on next page*

## Safe and Effective Use, Continued

---

### **Response to exposure** (continued)

Reactions can vary depending on the suspect's:

- physical condition
- psychological makeup
- degree of exposure to the agent
- use of alcohol or drugs

NOTE: Additional information regarding the effects of specific chemical agents is given later in this lesson.

---

### **Officer safety**

The time required for any effect to take place, the severity of the effect, and the recovery time can vary from one individual to another. Because no device is 100% effective, a determined assailant may be able to overcome the physical effects. For some individuals, the agent may have no effects at all.

Care should be taken before officers approach the suspect. Because of the varying degrees of effectiveness, officers should never expect immediate incapacitation and should always be prepared to overcome further resistance.

---

### **Decontamination**

Decontamination procedures should begin as soon as the exposed suspect has been properly restrained. At that time, officers should expose the person to fresh air. If necessary, the affected area on the person may also be flushed with water and washed with a nonoily-based soap (e.g., *Johnson's Baby Soap*).

NOTE: No salves, ointments, or moisturizing agents should be used on the affected areas of the person. Use of such materials could bond the chemical agent to the skin causing continued discomfort.

---

*Continued on next page*

## Safe and Effective Use, Continued

---

### Decontamination procedures

It is important that officers know simple procedures to administer to people affected by chemical agents. This knowledge will be useful whether the persons affected are the suspects or peace officers themselves.

The table below identifies basic decontamination procedures to use on people who have been exposed to chemical agents.

Area Affected	Symptoms	Decontamination Procedures
<b>Eyes</b>	<ul style="list-style-type: none"><li>• Burning sensation</li><li>• Heavy tearing</li><li>• Involuntary closing of eyes</li></ul>	<ul style="list-style-type: none"><li>• Keep eyes open facing wind</li><li>• Do not rub eyes</li><li>• Tearing helps clear eyes</li><li>• If agent particles remain in eyes, wash out with lots of cool water</li><li>• Blot tears away</li></ul>
<b>Skin</b>	<ul style="list-style-type: none"><li>• Stinging or burning sensation on moist skin areas</li><li>• Blisters from very heavy concentrations</li></ul>	<ul style="list-style-type: none"><li>• Have victim sit and remain quiet to reduce sweating</li><li>• Expose affected area to the air</li><li>• Gross contamination can be relieved by flushing with clear water for at least 10 minutes</li></ul>

---

*Continued on next page*

## Safe and Effective Use, Continued

---

**Decontamination procedures**

<b>Area Affected</b>	<b>Symptoms</b>	<b>Decontamination Procedures</b>
<b>Nose</b>	<ul style="list-style-type: none"><li>• Irritation, burning sensation</li><li>• Nasal discharge</li></ul>	<ul style="list-style-type: none"><li>• Person should breathe normally</li><li>• Blow nose to remove discharge</li><li>• Nose drops will help if discomfort is severe</li></ul>
<b>Chest</b>	<ul style="list-style-type: none"><li>• Irritation, burning sensation</li><li>• Coughing, feeling of suffocation</li><li>• Tightness in chest, often accompanied by a feeling of panic</li></ul>	<ul style="list-style-type: none"><li>• Person should relax and stay calm</li><li>• Talking reassuringly to the person will help to relieve discomfort and prevent panic</li></ul>

**NOTE:** For severe or prolonged exposure, medical aid should be sought as soon as possible.

---

*Continued on next page*

## Safe and Effective Use, Continued

---

### **Custody notification**

If an exposed suspect is taken into custody, custodial officers should be notified of the person's exposure to a chemical agent.

---

### **Examples**

- (1) Two officers arrived at a suspect's house to serve an arrest warrant. The suspect, a large male, appearing very agitated and hostile, refused to be taken into custody and ran into the backyard where he turned and challenged the officers. One officer pulled the chemical agent canister from his holster and sprayed the suspect in the eyes. The suspect dropped to his knees and the officers handcuffed him. They were able to serve the warrant without further incident.
  - (2) An officer sprayed a combative narcotic suspect with a chemical agent. After two applications, the officer realized that the agent was having very little effect due to the suspect's drug usage. The officer requested help and, once an adequate number of officers were present, the suspect was subdued and taken into custody.
  - (3) A combative inmate in a cell refused to come out of the cell when ordered to by deputies. The deputies opened the cell door, sprayed the inmate in the face, and then immediately rushed into the cell. The inmate was not instantaneously incapacitated by the chemical agent and fought with the deputies, injuring one severely. The deputies should have given the chemical agent time to take effect before engaging directly with the inmate.
- 

*Continued on next page*

## Safe and Effective Use, Continued

---

**Student notes**      During class, instructors will demonstrate the proper methods for safe and effective use of hand-held chemical agent canisters.



# OC (Oleoresin Capsicum)

[35.06.E07]

---

## Introduction

The chemical agent most widely used by both law enforcement and the general public is **OC** (oleoresin capsicum, pronounced *oleo-resin-cap-si-cum*), also commonly referred to as pepper spray.

---

## Characteristics

OC has a pungent and irritating pepper odor. It is classified as an inflammatory agent.

Besides being effective on humans, OC-based chemical agents usually work on animals as well. However, some animals, such as trained attack dogs, may not be affected.

---

## Makeup

In a liquid form, OC can appear as a clear, amber, or heavy dark red solution depending on the manufacturer. It is mixed with several different types of solutions which act as carriers. These solutions are then sprayed from aerosol canisters.

---

## Canisters

Most canisters used by law enforcement are black with orange, white, or red writing.

Even though a canister may have a color code reference marking, it is critical that officers examine closely the label of each canister to make sure of its contents.

NOTE: There is no industry standard on the open market.

---

*Continued on next page*

## OC (Oleoresin Capsicum), Continued

---

### Physiological effects

The following table identifies the most common physiological effects a peace officer can expect when OC is used:

<b>Area Affected</b>	<b>Possible Physical Response</b>
<b>Eyes</b>	<ul style="list-style-type: none"><li>• Heavy tearing due to a burning sensation</li><li>• Severe twitching</li><li>• Involuntary closing or blinking</li></ul>
<b>Skin</b>	<ul style="list-style-type: none"><li>• Burning sensation</li><li>• Stinging on exposed areas</li><li>• Some reddening with lighter skinned people</li></ul>
<b>Nose</b>	<ul style="list-style-type: none"><li>• Irritation and burning sensation</li><li>• Runny nose</li></ul>
<b>Mouth</b>	<ul style="list-style-type: none"><li>• Salivation</li><li>• Burning sensation</li></ul>
<b>Throat and Lungs</b>	<ul style="list-style-type: none"><li>• Coughing</li><li>• Gagging sensation</li><li>• Shortness of breath</li><li>• Temporary paralysis of the larynx (person unable to speak)</li></ul>
<b>Stomach</b>	<ul style="list-style-type: none"><li>• Nausea (caused by shock, not by the OC itself)</li></ul>

---

*Continued on next page*

## OC (Oleoresin Capsicum), Continued

---

### **Psychological effects**

A person may also experience any of the following psychological effects when exposed to OC.

- Disorientation
  - Anxiety
  - Panic
  - Aggression
- 

### **Recovery time**

Normally, a person who has been exposed to OC will experience considerable discomfort for a short period of time, and then begin to recover. Complete recovery usually takes place within 45-60 minutes.

Persons exposed to OC should be monitored during the recovery period. If the effects do not begin to diminish in a reasonable amount of time or if symptoms appear to indicate the person is having an unusual response (e.g., difficulty in breathing, unconsciousness, vomiting), further medical attention should be sought.

**NOTE:** Officers should be completely familiar with agency policy regarding positional asphyxiation.

---

*Continued on next page*

## OC (Oleoresin Capsicum), Continued

---

### Examples

- (1) Two officers arrived at a house to carry out a drug search warrant. An aggressive dog charged the officers as they reached the front door. One officer was ready to shoot the dog, but his partner, signaling the first officer to stay back, unholstered his canister of OC and sprayed the agent into the dog's eyes. The dog retreated, allowing the officers to enter and lock the dog in a room where he went to hide. The warrant was successfully executed without further need for force.
  - (2) Officers confronted an irate and hysterical suspect on a stairway, where he repeatedly swung a bat at officers when they tried to approach him. One officer deployed OC at a safe distance which overcame the suspect. He was then handcuffed and taken into custody.
  - (3) While chasing an arson suspect, officers tried to spray him with OC. Because OC requires a direct hit in the face, it was ineffective. In fact, one officer became incapacitated by the spray.
-

# CN (Chloroacetophenone) and CS Ortho-chlorobenzylidene-molonitrile)

[35.06.EO8, 35.06.EO9]

---

**Introduction** CN (chloroacetophenone, pronounced *chloro-aceto-fenone*) and CS (ortho-chlorobenzylidene-molonitrile, pronounced *ortho-chloro-benzil-ideen-malo-non-nitrile*) are two additional chemical agents that may be used by peace officers.

---

**Characteristics** The following table presents the different characteristics of CN and CS.

Chemical Agent	Characteristics
CN	<ul style="list-style-type: none"><li>• Odor, if any, of faint apple blossoms</li><li>• Classified as a lacrimator (tearing agent)</li><li>• Five times heavier than air</li><li>• Can displace the oxygen in an enclosed area</li><li>• Dispersed as a mixture of vapor and fine particle smoke by burning type munitions such as projectiles and grenades</li><li>• May appear as a bluish white cloud at the point of release</li></ul>
CS	<ul style="list-style-type: none"><li>• Pungent pepper-like odor</li><li>• Classified as a lacrimator (tearing agent/irritant)</li><li>• Can displace the oxygen in an enclosed area</li><li>• Faster acting, much stronger, but less toxic than CN</li><li>• Appears as a white cloud at the point of release</li><li>• Disseminated by burning, explosion, or aerosol</li><li>• May be used as a crowd control agent</li></ul>

---

*Continued on next page*

# CN (Chloroacetophenone) and CS Ortho-chlorobenzylidene-molonitrile), Continued

---

## Makeup

The following table presents the makeup of each chemical agent.

Chemical Agent	Make Up
CN	<ul style="list-style-type: none"><li>• An organic compound that, in pure form, is a white crystalline solid, resembling salt or sugar</li><li>• There are two types of CN:<ul style="list-style-type: none"><li>- a solid form used in grenades and projectiles</li><li>- a liquid form used in aerosol devices and projectiles</li></ul></li></ul>
CS	<ul style="list-style-type: none"><li>• A synthetic compound</li><li>• White crystalline solid, resembling talcum powder</li><li>• Particles are approximately one to ten microns in size (smaller than CN in its pure form)</li><li>• Particles are heavier than air</li></ul>

---

## Canisters

Each canister of a chemical agent should have a color code marking to help identify it from other forms of aerosol canisters containing chemical agents.

CN: *Red*

CS: *Blue*

Even though a canister may have a color code reference marking, it is critical that officers closely examine the label of each canister to make sure of its contents.

Military CN canisters will vary in color. Should you encounter military CN ordnance keep in mind that there are no standardized colors used to identify CN canisters.

---

*Continued on next page*

## CN (Chloroacetophenone) and CS Ortho-chlorobenzylidene-molonitrile), Continued

### Physiological effects

The following table identifies the most common physiological effects for CN and CS.

Area Affected	CN	CS
<b>Eyes</b>	<ul style="list-style-type: none"> <li>• Profuse tearing and burning</li> <li>• Involuntary closing, usually within one or two seconds</li> </ul>	<ul style="list-style-type: none"> <li>• Heavy tearing and burning</li> <li>• Involuntary closure</li> </ul>
<b>Skin</b>	<ul style="list-style-type: none"> <li>• Burning sensation, especially if suspect is hot and perspiring</li> <li>• Blistering from heavy concentrations</li> </ul>	<ul style="list-style-type: none"> <li>• Stinging on exposed and moist areas</li> <li>• Blistering from heavy concentration</li> </ul>
<b>Nose</b>	<ul style="list-style-type: none"> <li>• Irritation and burning sensation, usually occurring within one to two seconds</li> <li>• Runny nose</li> </ul>	<ul style="list-style-type: none"> <li>• Irritation and burning</li> <li>• Runny nose</li> </ul>
<b>Mouth</b>	<ul style="list-style-type: none"> <li>• Salivation</li> </ul>	<ul style="list-style-type: none"> <li>• Heavy salivation</li> </ul>
<b>Throat and Lungs</b>	<ul style="list-style-type: none"> <li>• Irritation</li> <li>• Coughing and tightness in chest</li> </ul>	<ul style="list-style-type: none"> <li>• Throat irritation</li> <li>• Coughing and tightness in chest</li> <li>• Shortness of breath</li> </ul>

*Continued on next page*

## CN (Chloroacetophenone) and CS Ortho-chlorobenzylidene-molonitrile), Continued

Physiological effects  
(continued)

Area Affected	CN	CS
<b>Stomach</b>	<ul style="list-style-type: none"> <li>Nausea from high concentrations or extended exposures</li> </ul>	<ul style="list-style-type: none"> <li>Nausea from high concentrations or extended exposures</li> </ul>
<b>Central Nervous System</b>	<ul style="list-style-type: none"> <li>Headache</li> </ul>	<ul style="list-style-type: none"> <li>Headache</li> </ul>

A person may experience any of the following psychological effects when exposed to CN and CS.

Chemical Agent	Psychological Effect
<b>CN</b>	<ul style="list-style-type: none"> <li>Anxiety, caused by the level of physical discomfort</li> <li>Mildest of the chemical irritants with the least psychological impact, although individual reactions may vary</li> </ul>
<b>CS</b>	<ul style="list-style-type: none"> <li>Anxiety</li> <li>Panic/fear</li> <li>Disorientation</li> </ul>

*Continued on next page*



## CN (Chloroacetophenone) and CS Ortho-chlorobenzylidene-molonitrile), Continued

---

### Recovery time

Everyone who has been exposed to a chemical agent should be monitored during their recovery period. If the effects of the agent do not begin to wear off in a reasonable amount of time or if symptoms appear to indicate the person is having an extreme reaction, medical attention should be sought.

The following table identifies approximate recovery times for CN and CS.

<b>Chemical Agent</b>	<b>Approximate Recovery Time</b>
CN	10-20 minutes
CS	10-20 minutes

---

# Gas Masks

[35.06.EO10, 35.06.EO11]

---

## Introduction

A **gas mask** is a device that mechanically filters minute solid particles and liquid droplets from the air. Present day gas masks use activated nut charcoal or other absorbents to accomplish this function.

---

## Agency specific equipment

Different law enforcement agencies may issue different makes and models of gas masks. The specific procedures for fit, care, maintenance, cleaning, etc. may vary according to the specific type of mask issued.

This lesson addresses a number of principles and procedures which are basic to most types of gas masks.

---

## Components

Modern day gas masks used by peace officers should have three essential components. The following table identifies each.

Component	Gas masks used by peace officers should:
<b>Lens</b>	<ul style="list-style-type: none"><li>protect the eyes from exposure to the chemical agent and still allow for adequate peripheral vision</li></ul> <p>NOTE: Masks should be evaluated by each officer to determine the amount of peripheral vision it will allow. This can be tested by extending the arms outward to the sides while wearing the mask. Peripheral vision is the area that can be seen by scanning the area without moving the head.</p>
<b>Surface</b>	<ul style="list-style-type: none"><li>cover the face sufficiently to enclose the officer's mouth, nostrils, and eyes while permitting a good seal</li></ul>
<b>Filtering Device</b>	<ul style="list-style-type: none"><li>filter out solid particles as well as micro-droplets of chemical agents</li></ul>

---

*Continued on next page*

## Gas Masks, Continued

---

### Limitations

While a properly fitting and operating gas mask will filter out minute solid particles and liquid droplets, it will not filter out:

- odors
- smoke
- true gasses (e.g., carbon monoxide)
- chemical gasses that may be present in hazardous locations such as clandestine drug labs

NOTE: Gas masks should not be confused with self-contained breathing devices (industrial respirators). Such devices provide a totally separate supply of oxygen. A gas mask will only filter particles from the existing air.

NOTE: There may still be a number of gas masks and filters used by law enforcement agencies that are not capable of filtering CS particles.

---

### Inspection

Before putting on any gas mask, the officer should examine the mask closely and check:

- the appearance of the entire mask, looking for signs of damage
- for missing, cracked, or scratched lenses
- the condition of all intake and exhaust valves or covers
- for worn or broken head straps
- for appropriate filters
- to see that the mask is an appropriate size

NOTE: Do not over tighten filters

---

*Continued on next page*

## Gas Masks, Continued

---

### Proper fit

When first used, the following procedures should be followed to ensure that the gas mask fits properly before entering a contaminated area.

Step	Procedures to Ensure Proper Fit
1	Loosen all adjusting straps
2	Place chin in the mask chin rest
3	Raise the head harness over the back of the head
4	Tighten the head straps as appropriate from bottom to top.
5	Clear the mask
6	Seal the mask  The mask is airtight if it pulls against the face and remains there while breath is being held.

NOTE: If the mask does not fit properly, the officer should repeat the tightening of the head harness. If leaks continue, the mask should be reinspected and replaced if necessary.

---

### Clearing

Clearing the mask is purging it of contaminants in a contaminated environment. To clear the mask, blow out vigorously several times.

NOTE: Leave mask on until sufficiently clear of contaminated area.

---

### Filters

Filters should be stored in sealed canisters in a cool, dry location.

The life of the filter used in a gas mask is dependent on its individual usage and storage. Most filters will normally last for several years if unopened.

---

*Continued on next page*

## Gas Masks, Continued

---

### Cleaning

Gas masks should be thoroughly cleaned after each exposure or at least twice each year. The following table identifies the procedures for cleaning most masks:

Step	Procedures for Cleaning
1	Remove the filters
2	Wash with mild soap and water
3	Rinse thoroughly with warm to hot water
4	Dry completely with a warm to hot current of air
5	Inspect for any chemical agent residue
6	Re-clean if necessary

NOTE: Some of the newer types of masks with non-rubber composition require special care and servicing. Officers who have these types of masks should refer to the manufacturer's instructions.

---

### Storage

A gas mask should be stored in a container that will protect it from dirt, heat, and moisture.

---

### Examples

- (1) One officer, after being issued a new gas mask, inspected it thoroughly and discovered that it did not provide an airtight fit, even after repeatedly adjusting the head harness. She requested and received a replacement mask.
- 

*Continued on next page*

## Gas Masks, Continued

---

**Examples**  
(continued)

- (2) All members of a SWAT team donned their gas masks before entering a building full of tear gas. After a lengthy and exhausting search, several officers, on leaving the building, immediately pulled their masks off. Because the tear gas was filtering out the front door, officers had a residual chemical agent on their clothing, and they were exposed to the agent.
- 

*Continued on next page*

## Gas Masks, Continued

---

**Student notes**      During class, instructors will demonstrate the proper use and care of gas masks.

# Chapter Synopsis

---

**Learning need** Peace officers must know the terminology, capabilities, exposure symptoms, and decontamination procedures in order to safely and effectively handle and deploy chemical agents and gas masks.

---

**Possession of tear gas [35.01.EO1]** *Penal Code Section 22900* states that it is a misdemeanor crime to possess a chemical agent if that person:

- knowingly possesses, sells or offers for sale, or transports,
  - any prohibited tear gas or tear gas weapon,
  - *except when otherwise permitted.*
- 

**Chemical agent deployment methods [35.01.EO3]** There are four primary methods for deploying chemical agents.

---

**Conditions impacting effectiveness [35.01.EO4]** All methods for deploying chemical agents can be affected by environmental and physical conditions. Officers should recognize these conditions and take appropriate precautions before deploying a chemical agent.

---

**Safe use of hand-held canisters [35.01.EO5]** All hand-held canisters should be maintained according to the manufacturer's specifications.

---

*Continued on next page*



## Chapter Synopsis, Continued

---

**Decontamination procedures**  
[35.01.EO6]

It is important that officers know simple procedures to administer to persons affected by chemical agents.

---

**OC**  
[35.01.EO7]

The chemical weapon most widely used by both law enforcement and the general public is OC (oleoresin capsicum), also commonly referred to as pepper spray.

---

**CN and CS**  
[35.06.EO8,  
35.06.EO9]

CN and CS are two additional chemical agents that may be used by law enforcement officers.

---

**Inspection and fit of gas masks**  
[35.06.EO10]

The officer should examine the mask closely and check:

- the appearance of the entire mask, looking for signs of damage
  - for missing, cracked, or scratched lenses
  - the condition of all intake and exhaust valves or covers
  - for worn or broken head straps
  - for appropriate filters
  - to see that the mask is an appropriate size
- 

**Cleaning and storage of gas masks**  
[35.06.EO11]

Gas masks should be thoroughly cleaned after each exposure or at least twice each year. Gas masks should be stored in containers which will protect them from dirt, heat, and moisture.

---

# **Workbook Learning Activities**

---

## **Introduction**

To help you review and apply the material covered in this chapter, a selection of learning activities has been included. No answers are provided. However, by referring to the appropriate text, you should be able to prepare a response.

---

## **Activity questions**

1. Under what conditions, if any, is the possession of OC, CN, or CS legal for a 20 year old California resident? Consider each agent separately.
  
2. A controversial political rally has turned into a riot. Officers are evaluating the use of CS for controlling and dispersing the crowd. How could weather conditions affect the decision? What other factors should be considered in deciding whether to use CS?

---

*Continued on next page*

## Workbook Learning Activities, Continued

---

**Activity questions**  
(continued)

3. Identify two methods for deploying chemical agents. For each method, give an example showing when that method might be used successfully.
4. A 200 pound intoxicated suspect resists arrest by a 140 pound officer. The suspect becomes aggressive and begins to approach the officer. The officer decides to deploy OC. What should the officer do to make the most effective use of the OC?

---

*Continued on next page*

## Workbook Learning Activities, Continued

---

**Activity  
questions**  
(continued)

5. What does it mean if an officer in a chemical agent environment inhales deeply and her gas mask remains loosely fitted to her face?

6. What is the purpose of color coding on chemical agent canisters? What colors distinguish OC and CS respectively? Since color coding exists, do you think it is necessary for officers to read canister labels for contents? Why or why not?

# Supplementary Material

## Graphic Illustrations

---

**In this section** Refer to the following table for specific reference documents included in this section.

<b>Graphic Illustrations</b>	<b>See Page</b>
Semiautomatic Pistol: Exterior	S-2
Semiautomatic Pistol: Interior	S-3
Semiautomatic Pistol: Magazine	S-4
Revolver	S-5
Shotgun	S-6
Handgun Cartridge	S-7
Shotgun Shell	S-8
Sight Alignment	S-9
Hand-Held Chemical Agent Aerosol Canister	S-10
Target Analysis for a Right Handed Shooter	S-11
Target Analysis for a Left Handed Shooter	S-12
Target Analysis for a Right Handed Shooter	S-13
Target Analysis for a Left Handed Shooter	S-14

## Semiautomatic Pistol: Exterior

---

### Basic components

The following graphic identifies the basic external components of a semiautomatic pistol. For additional information regarding the function of each component, refer to **Chapter 2: Basic Firearm Nomenclature and Operation**.

---

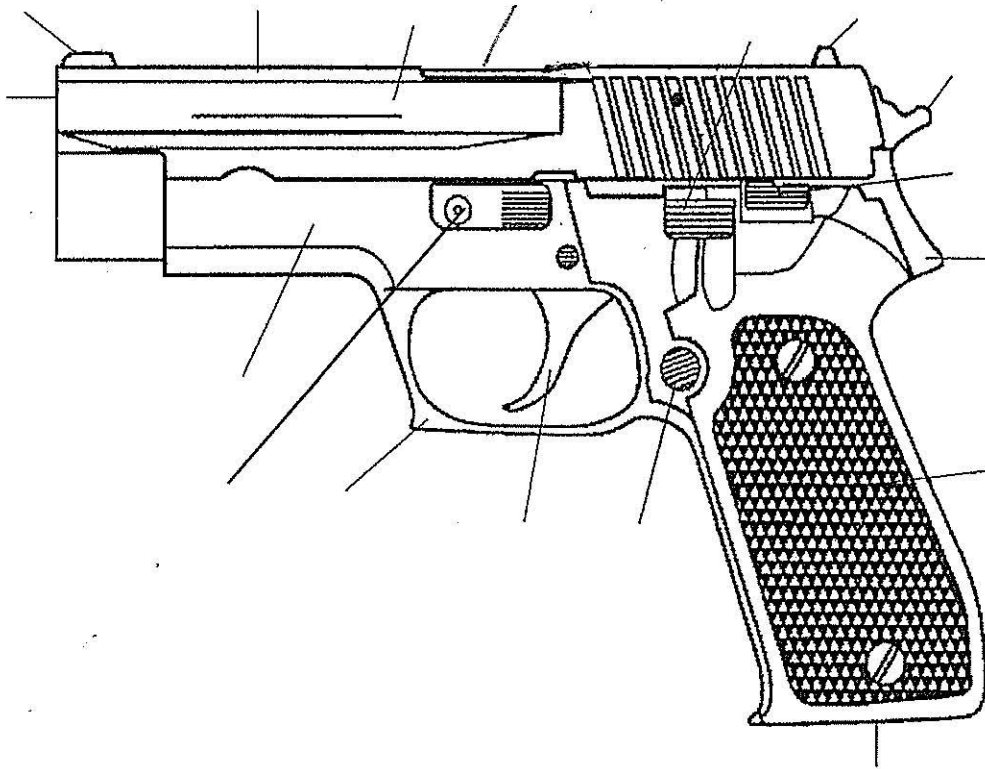

## Semiautomatic Pistol: Interior

---

### Basic components

The following graphic identifies the basic internal components of a semiautomatic pistol. For additional information regarding the function of each component, refer to **Chapter 2: Basic Firearm Nomenclature and Operation**.

---

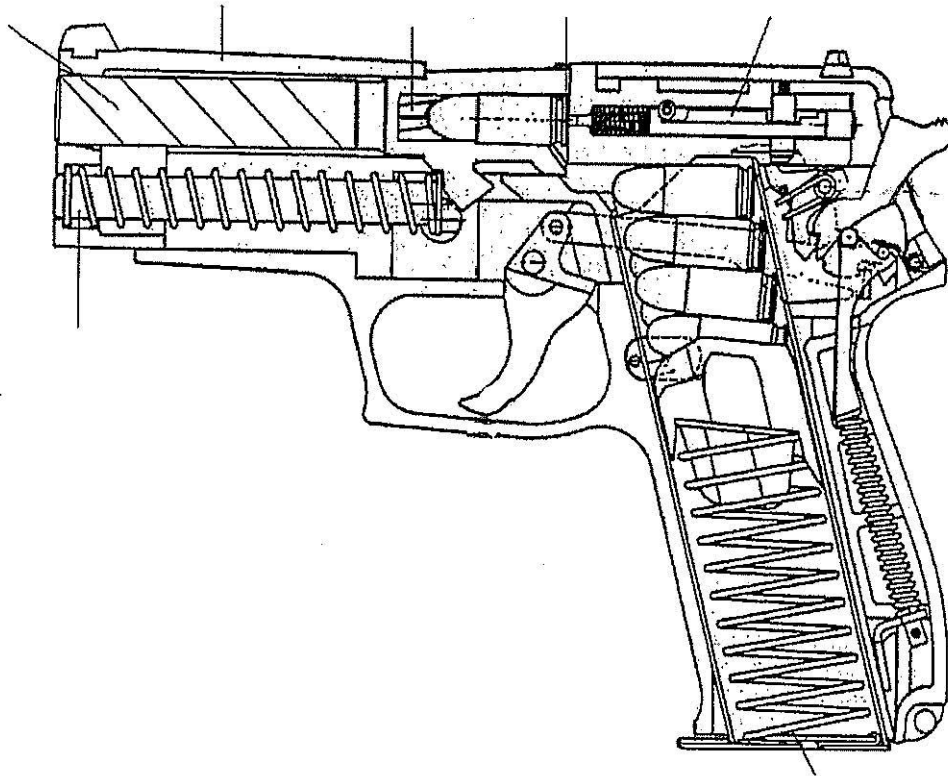

## Semiautomatic Pistol: Magazine

---

### Basic components

The following graphic identifies the basic components of a semiautomatic pistol magazine. For additional information regarding the function of each component, refer to **Chapter 2: Basic Firearm Nomenclature and Operation**.

---

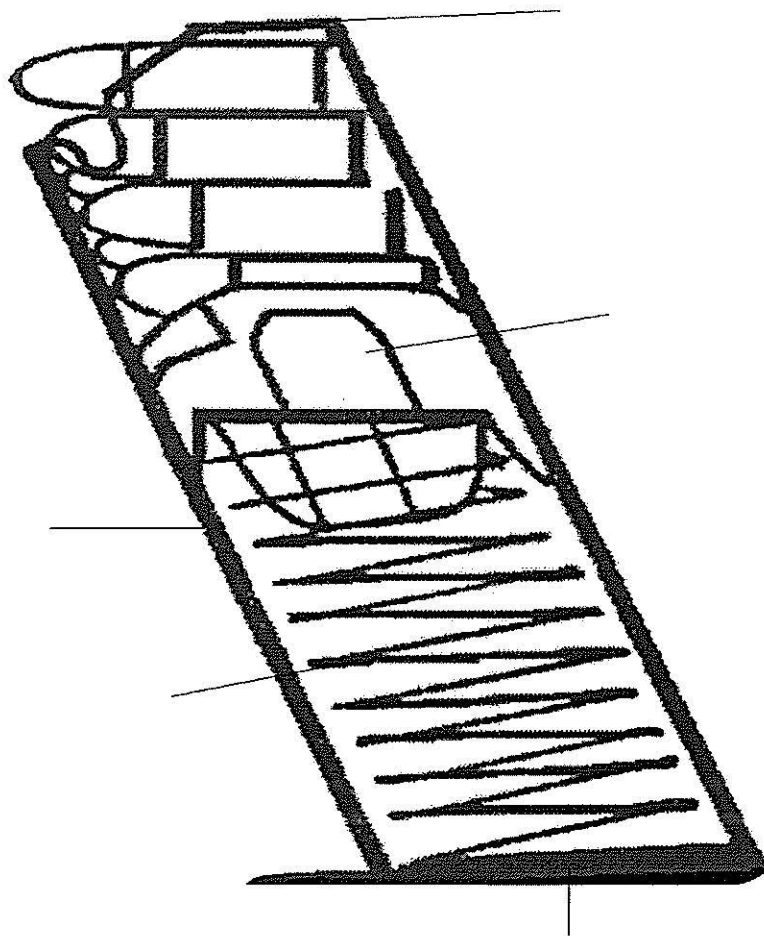



# Revolver

---

## Basic components

The following graphic identifies the basic components of a revolver. For additional information regarding the function of each component, refer to **Chapter 2: Basic Firearm Nomenclature and Operation**

---

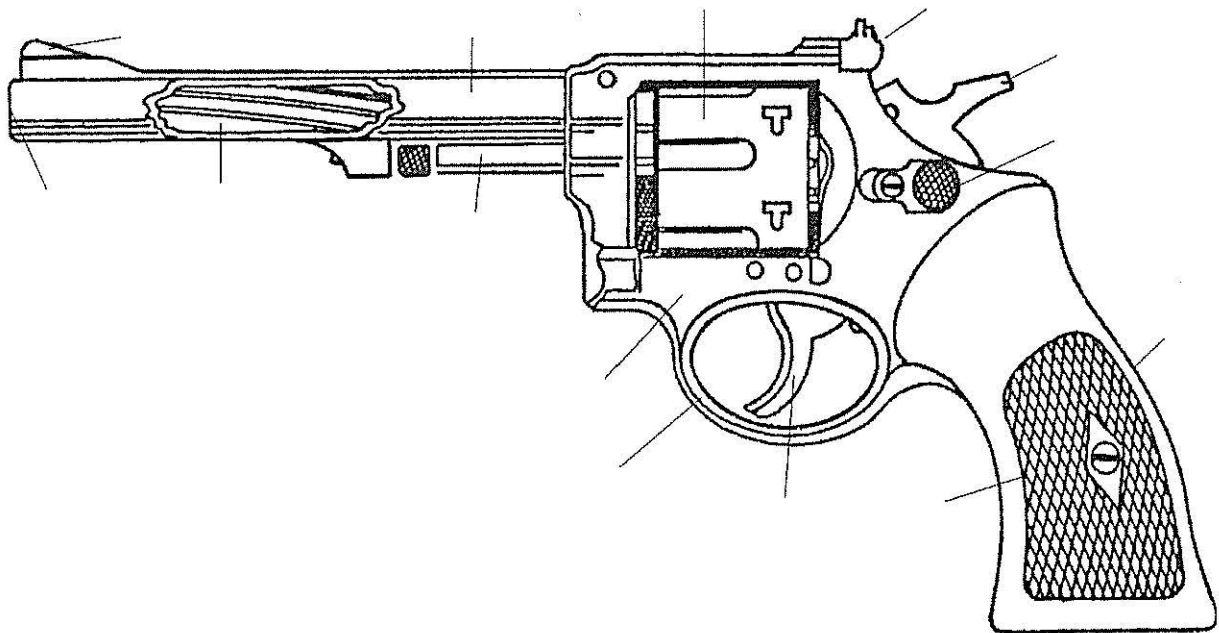

# Shotgun

---

## Basic components

The following graphic identifies the basic components of a shotgun. For additional information regarding the function of each component, refer to **Chapter 2: Basic Firearm Nomenclature and Operation.**

---

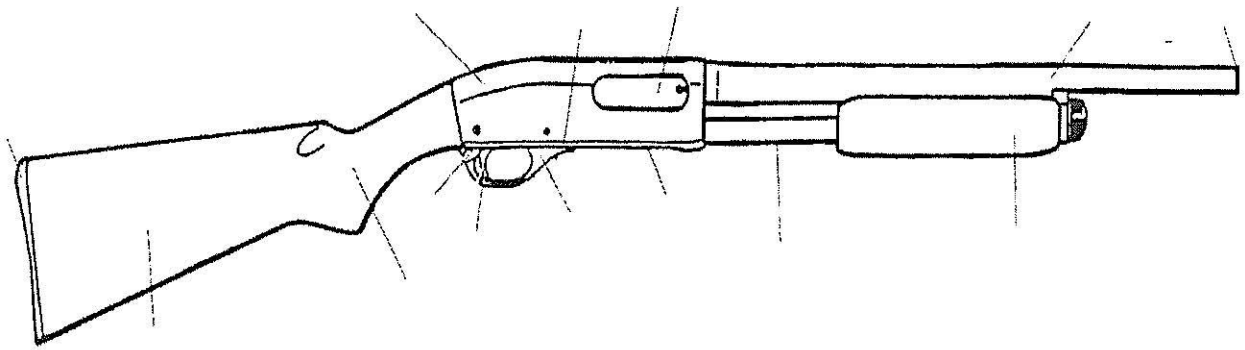

# Handgun Cartridge

---

## Basic components

The following graphic identifies the basic components of a handgun cartridge. For additional information regarding the function of each component, refer to **Chapter 3: Firearm Ammunition.**

---

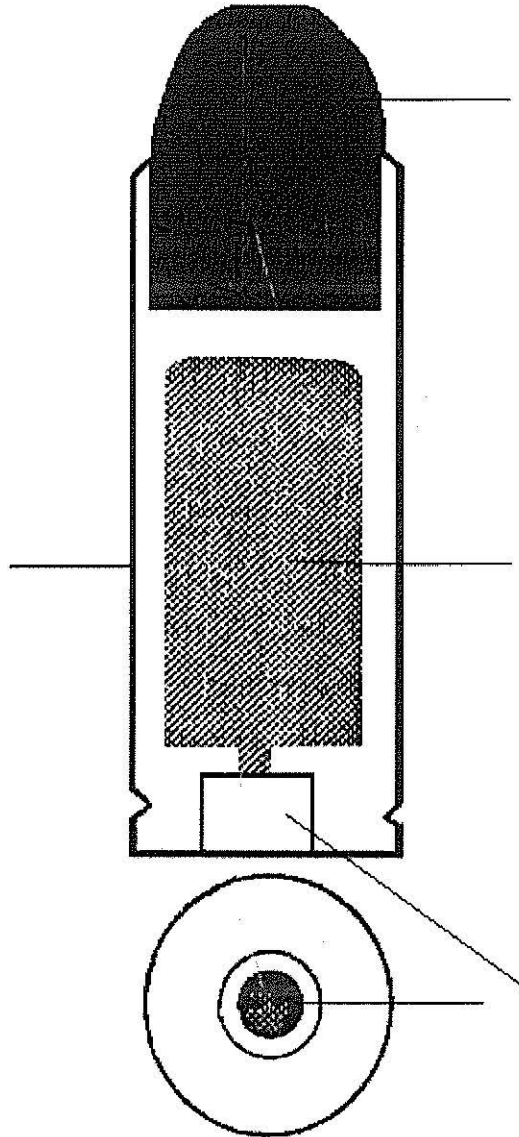

# Shotgun Shell

---

## Basic components

The following graphic identifies the basic components of a shotgun shell. For additional information regarding the function of each component, refer to **Chapter 3: Firearm Ammunition.**

---

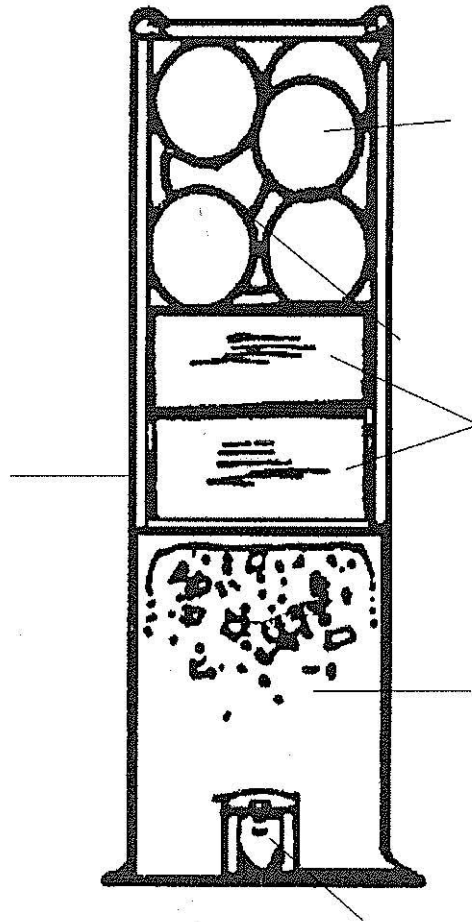

# Sight Alignment and Sight Picture

---

## Sight alignment and sight picture

The following graphics illustrate the concepts of sight alignment and sight picture. For additional information regarding sight alignment, refer to **Chapter 5: Principles of Shooting Accuracy**.

---

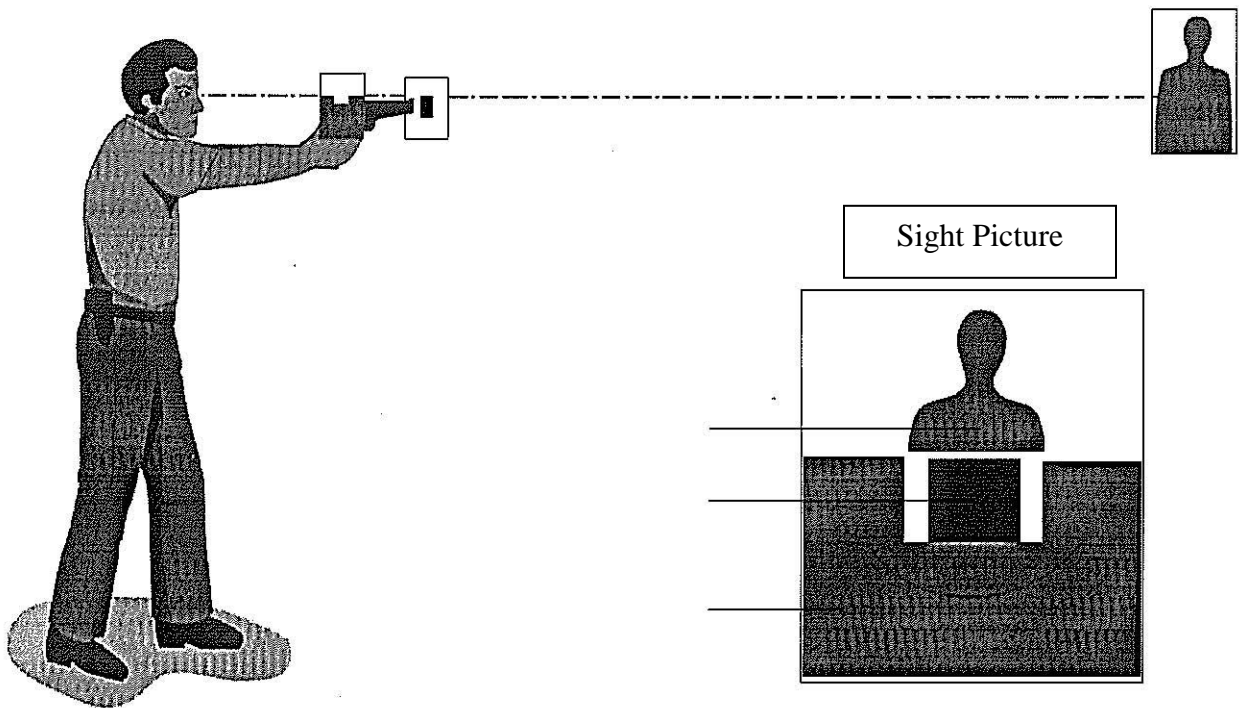

# Hand-Held Chemical Agent Aerosol Canister

---

## Basic components

The following graphic identifies the basic components of a hand-held chemical agent aerosol canister. For additional information regarding the function of each component, refer to **Chapter 6: Chemical Agents**.

---

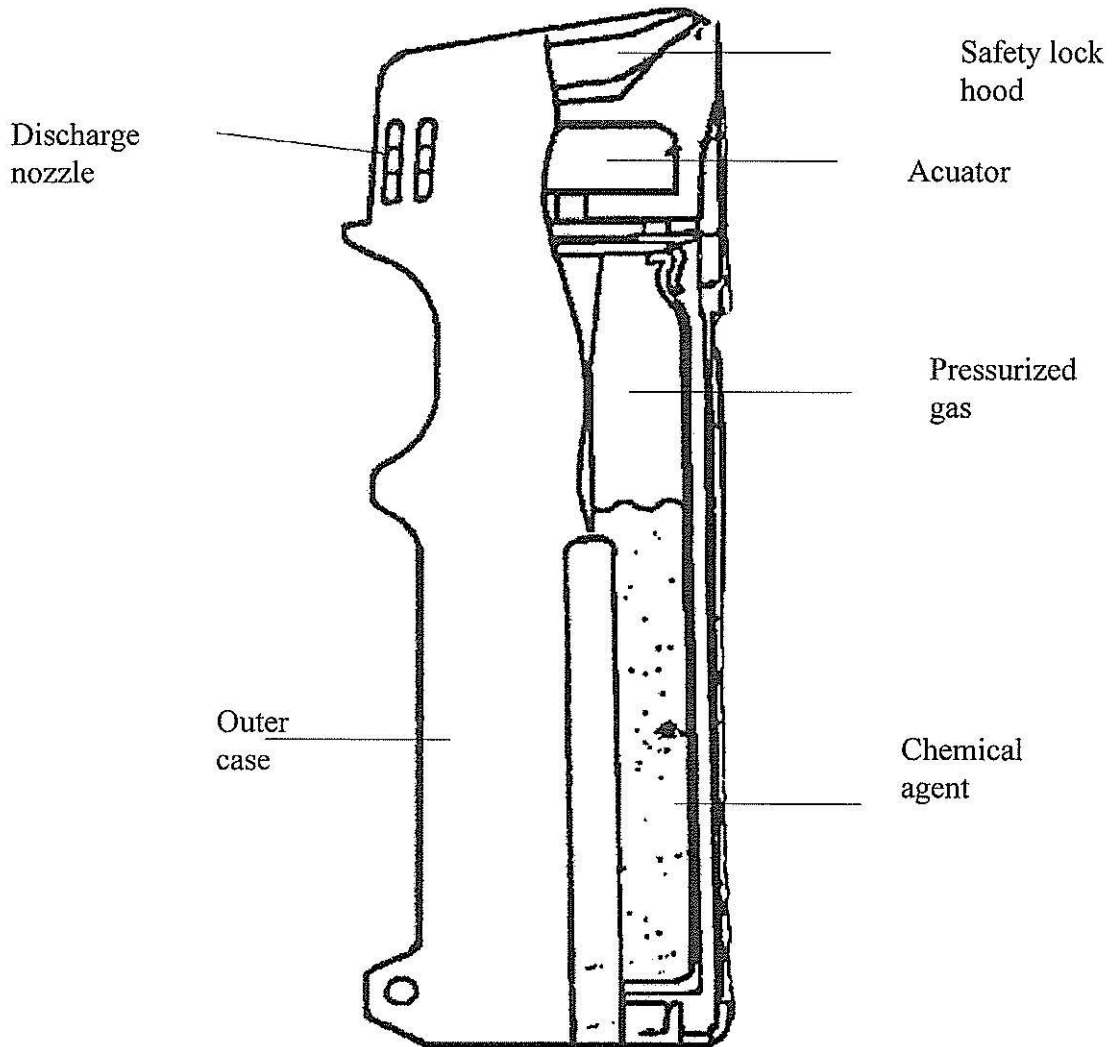

# Target Analysis for a Right Handed Shooter

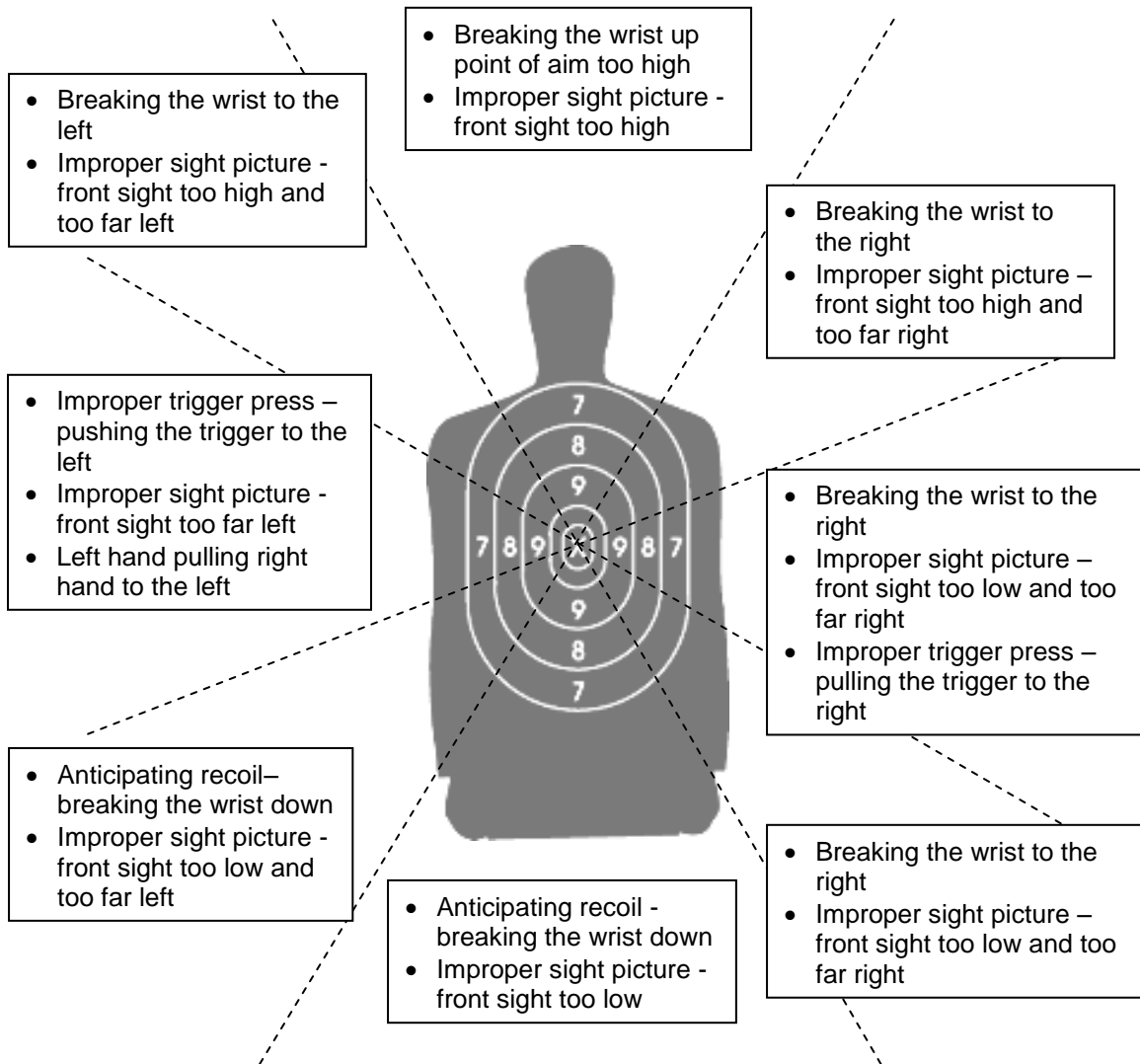

NOTE: For more information on sight alignment and sight picture see Chapter 5: Basic Shooting

# Target Analysis for a Left Handed Shooter

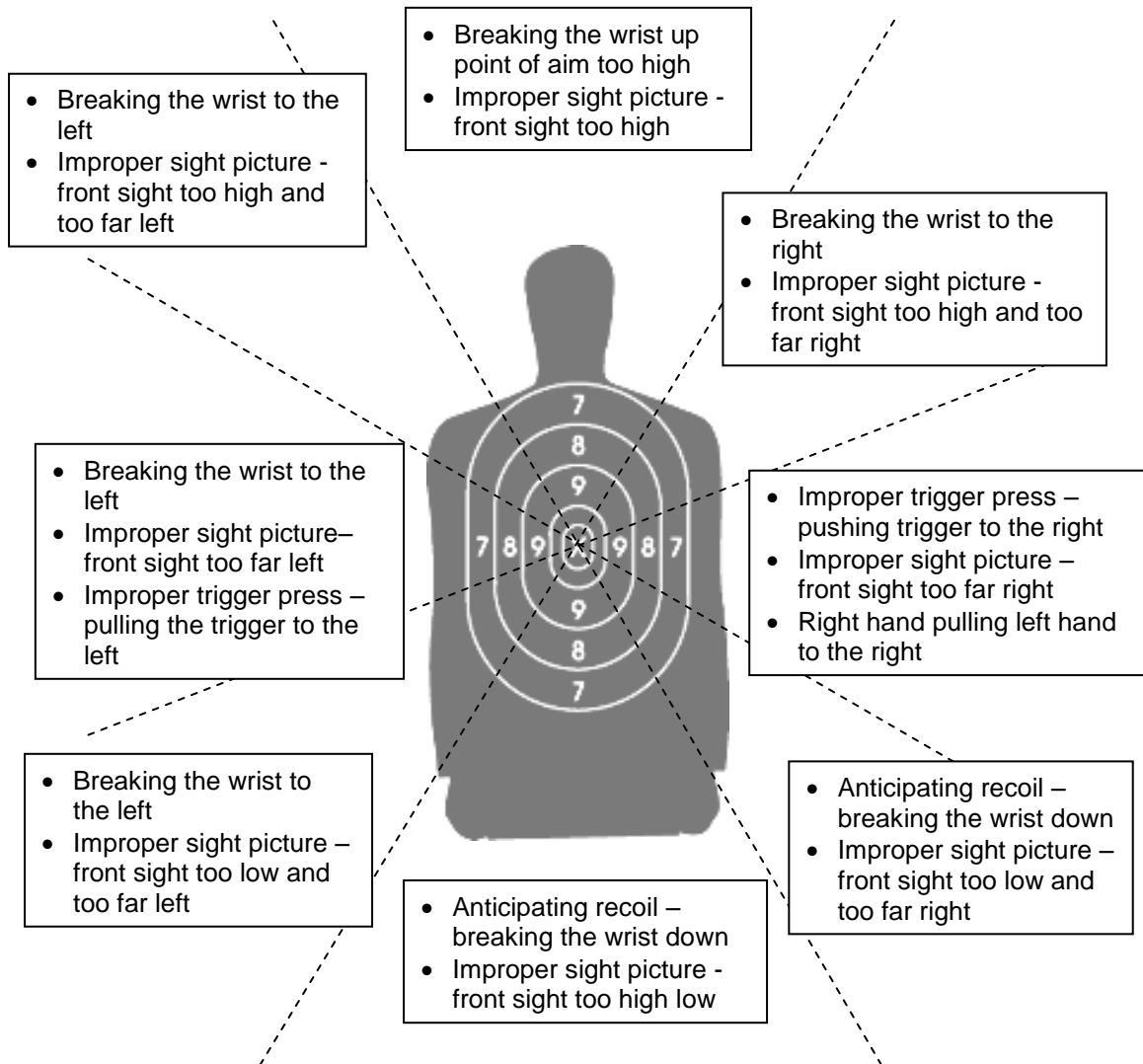



# Target Analysis for a Right Handed Shooter

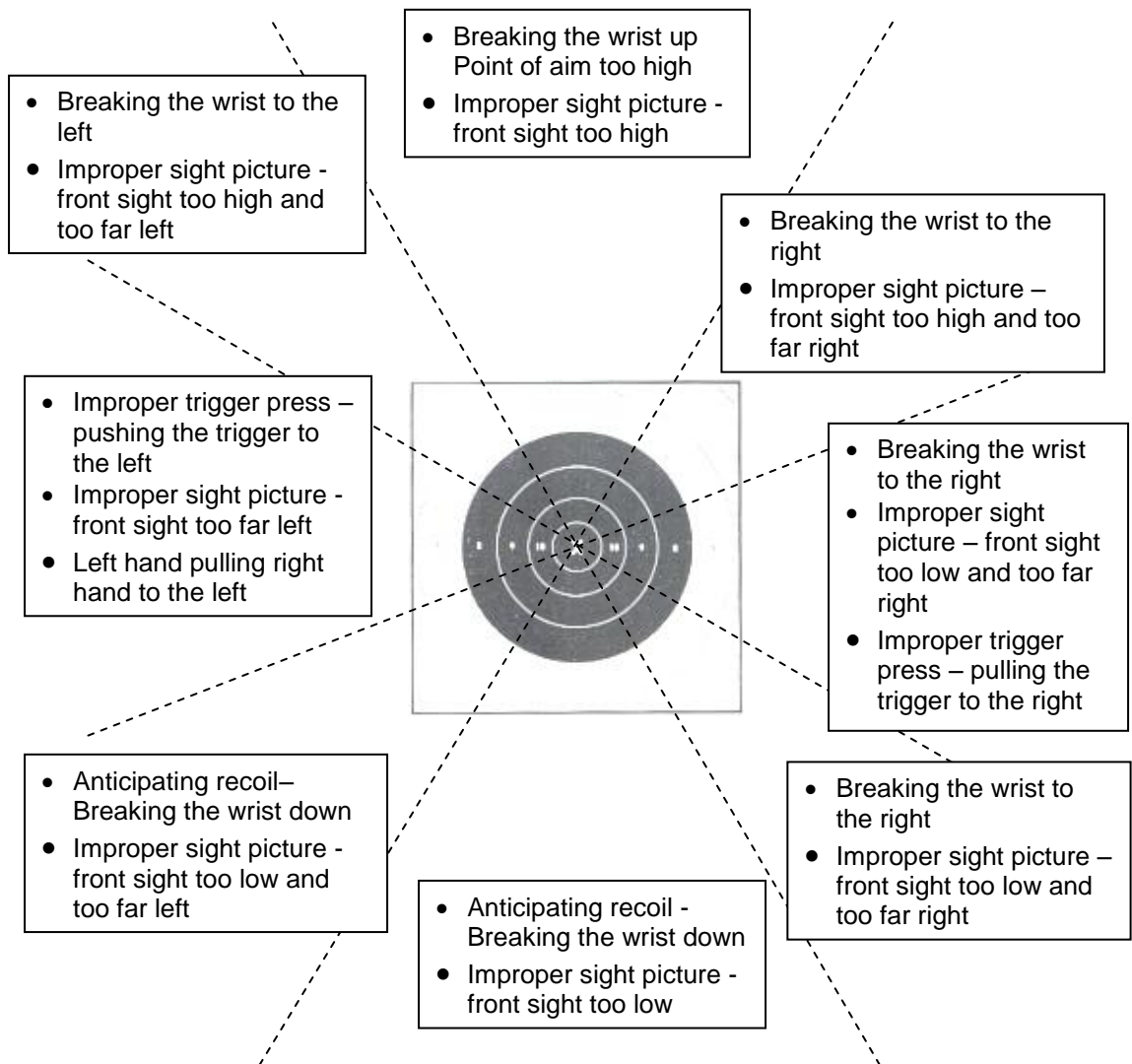

# Target Analysis for a Left Handed Shooter

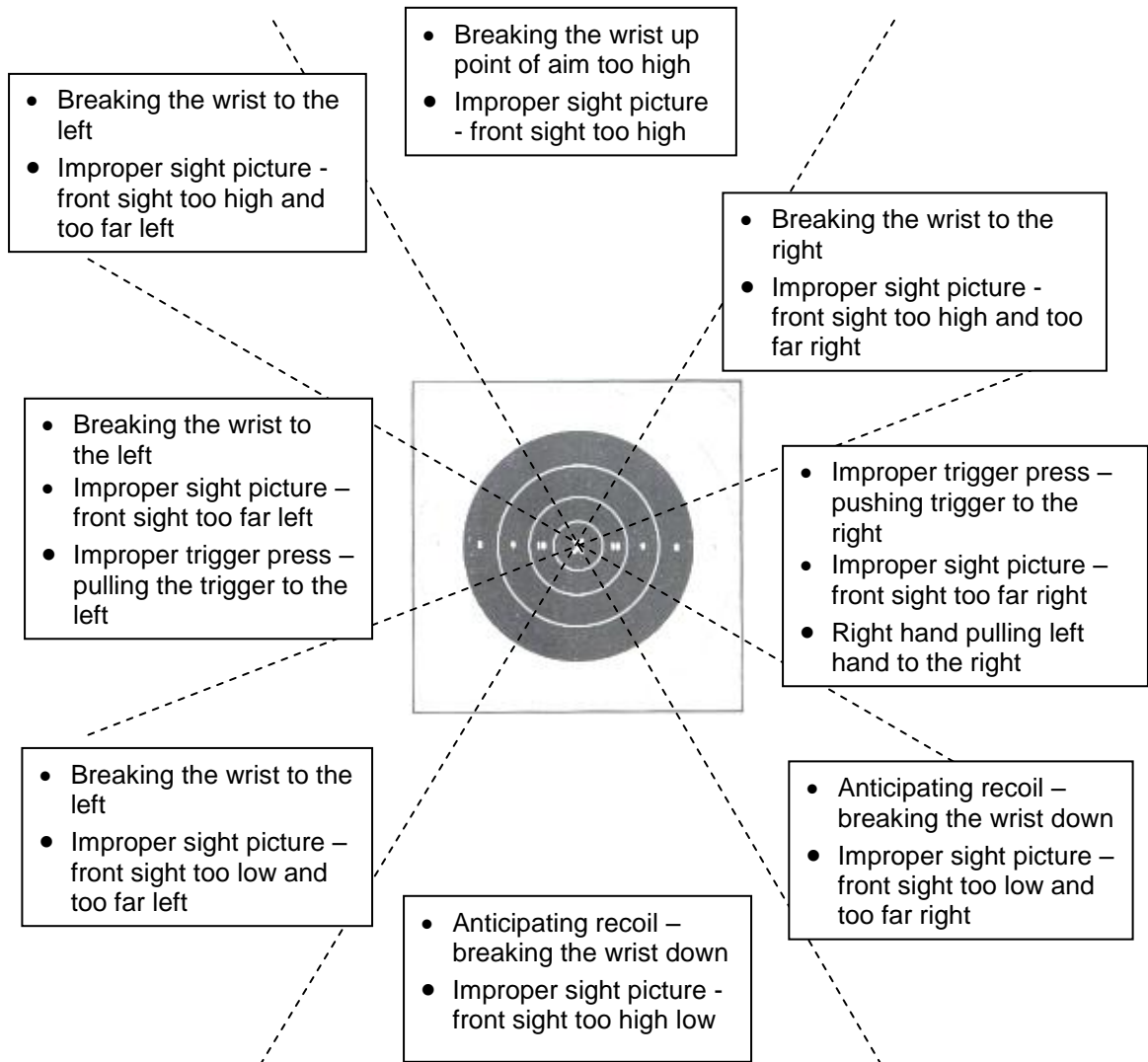

# Glossary

---

**Introduction**      **The following glossary terms apply only to Learning Domain 35:  
Firearms/Chemical Agents.**

---

**action**              The assembly of functional parts which move when the trigger is pulled,  
causing the firearm to fire

---

**ammunition**        The general term applied to cartridges and shotgun shells used as firearm  
projectiles

---

**anger**              A feeling of displeasure from a perceived injury, mistreatment, or opposition  
to oneself or to another person

---

**armorer**            Individual who is factory authorized to inspect and repair firearms

---

**automatic  
firearm**              A firearm that will load and fire automatically and continuously with a single  
pull and hold of the trigger until the magazine is empty

---

**ballistics**         The general study of projectiles in flight

---

**base  
plate**                An external plate that holds in the contents of the magazine

---

**blank  
shell**                A cartridge which contains an explosive charge but without a bullet

---

**buckshot**          The largest and most commonly used shot contained in shotgun shells

---

**caliber**            The diameter of a projectile; measured in hundredths of an inch or in  
millimeters

---

*Continued on next page*

## Glossary, Continued

---

**cartridge** A self-contained unit which includes a projectile and propellant capable of firing the projectile through the barrel of a firearm

---

**chamber check** The visual and physical verification of the condition of the firearm to determine if a round is in the chamber (also referred to as a press check)

---

**chemical agent device** Any shell, cartridge, or bomb capable of being discharged or exploded which allows the release of a chemical agent

---

**clearing** The process of completely emptying all cartridges/shells from a firearm and rendering it safe

---

**CN** Chloroacetophenone; widely used chemical agent that is the base chemical in many “Mace” products

---

**combat** Armed fighting where a peace officer is engaged in a confrontation that may result in great bodily injury or death

---

**concealment** Anything that prevents an opponent from observing an officer

---

**cover** Anything that may stop or deflect an opponent’s bullet

---

**CS** Ortho-chlorobenzylidene-malononitrile; chemical agent often used for riot control

---

*Continued on next page*

## Glossary, Continued

---

<b>cycle of operation</b>	The entire process of pulling the trigger to load a semiautomatic firearm, firing a cartridge, ejecting the cartridge, cocking the hammer, and a new cartridge loading into the chamber
<b>deadly force</b>	Any force that is likely to cause death or serious bodily injury
<b>decocking</b>	Process of safely releasing the hammer of a firearm to its forward position and returning the firearm to a double-action mode
<b>discharge</b>	emit, unload, to release the charge – shoot
<b>double-action</b>	A method of shooting a firearm where pulling the trigger begins a complete cycle of operation to fire the firearm
<b>drawing</b>	The removal of a firearm from the holster
<b>dry firing</b>	The act or result of pulling the trigger of an unloaded firearm, for the purpose of practice shooting or testing the firearm
<b>ejection port</b>	Opening where spent casings are expelled from the shotgun
<b>ejector</b>	Pushes the spent casing from the ejection port
<b>extractor</b>	the extractor pulls the casing out of the handgun's chamber
<b>fear</b>	A normal emotional response to a perceived threat

---

*Continued on next page*

## Glossary, Continued

---

**fight** An encounter in which a peace officer must overcome hostile resistance to a lawful exercise of authority

---

**field strip** The partial disassembly, complete wipe down and visual inspection of the primary parts of the handgun and magazine

---

**firing pin** Part of the handgun which strikes the primer of the cartridge

---

**floor plate** An internal device which holds the follower and spring in place

---

**follow-through** The continuation of grip, stance, breath control, sight alignment, and trigger control after a shot has been fired

---

**gas mask** A device that mechanically filters minute solid particles and liquid droplets from the air

---

**grain** Unit of weight of a projectile

---

**grip** The manner in which the firearm is held; also the term used to refer to the handle of the handgun

---

**holstering** The placing of a handgun into the officer's holster so that it is secure and available for use

---

*Continued on next page*

## Glossary, Continued

---

<b>in battery</b>	When the action of a firearm is in the firing position
<b>incapacitation</b>	The total removal of a person's ability or power to act
<b>jacket</b>	A metal envelope that encloses or partially encloses the bullet within a cartridge
<b>load</b>	The projectile(s) that are contained in a shotgun shell
<b>lubricants</b>	Substance used to protect metal parts, reduce friction, and cover a surface with a protective coating
<b>magazine</b>	A container that holds cartridges and fits inside the magazine well of a semiautomatic firearm
<b>malfunction</b>	An unexpected interruption in the firing sequence. Some malfunctions may be cleared (fixed) by the officer
<b>OC</b>	Oleoresin capsicum; chemical agent most widely used by both law enforcement and the general public; also commonly referred to as pepper spray
<b>out of battery</b>	When any portion of the action is out of the firing position

---

*Continued on next page*

## Glossary, Continued

---

**racking** The process of operating the action of a firearm to chamber a round

---

**revolver** A handgun equipped with a revolving cylinder that can contain several cartridges and can be fired repeatedly without being reloaded until the cylinder is empty

---

**rifled slug** A shotgun shell with a single round nose projectile

---

**round** A single cartridge

---

**semiautomatic firearm** A firearm that will load and fire only *one cartridge* automatically with a single pull

---

**semiautomatic pistol** A handgun that features a magazine which holds cartridges that self-load into the firing chamber automatically

---

**shell** A single unit of ammunition used in a shotgun

---

**shot** Small round projectiles contained in a shotgun shell

---

**shotgun** A smooth-bored firearm designed to be fired from the shoulder with two hands; primarily intended for firing multiple projectiles at one time

---

*Continued on next page*



## Glossary, Continued

---

**shot pattern** The diameter of the circle in which the spreading shot that has just been fired from a shotgun will fit

---

**sight alignment** The relationship between the shooter's eye, and the front and rear sights of the firearm

---

**sight picture** When the shooter's focus is on the top center of the *front sight* and the rear sight and aiming point (target) is out of focus

---

**single-action** A method of shooting a firearm where the hammer is cocked before the firearm is fired

---

**solvents** A toxic liquid substance capable of loosening, dissolving, or helping to remove dirt, grime, lead deposits, powder residue, copper, and grit from a firearm

---

**speedloader** A device that can be used to load cartridges into a revolver, filling the entire cylinder in one step

---

**squib load** The partial burning of a powder charge in a cartridge can result in insufficient force to propel the bullet out of the firearm

---

**stance** The physical positioning of the shooter's body when preparing to shoot a handgun or shotgun

---

*Continued on next page*

## **Glossary, Continued**

---

**stress**

A nonspecific response of the body to any demand made on it.

---

**tear  
gas**

All liquid, gaseous, or solid substances intended to produce temporary discomfort or permanent injury through being vaporized or otherwise dispersed in the air (*Penal Code Section 17240*)

---

**trigger  
control**

The process of using smooth continuous pressure on the trigger without disturbing the sight picture

---

**wound  
ballistics**

A study of how a fired projectile affects tissue

---

